



Pro V2 Mounting & Assembly Manual

1.1 — Last update: 26 February 2025

DOM Group

Table of Contents

1. About this manual and manufacturer information	5
1.1. Keep the manual available	6
1.2. Text layout features	7
1.3. Mutually applicable documents	8
1.4. Warranty and liability	9
1.5. Copyright	10
1.6. Documentation Officer	11
1.7. Manufacturer's address	12
2. Safety and security	13
2.1. Intended use	14
2.2. Ambient conditions	15
2.3. Fundamental safety information	16
2.3.1. Avoid risks of explosion	17
2.3.2. Preventing risk of injury due to swallowing small parts	18
2.3.3. Preventing serious injury or death caused by an EE (Emergency Exit) cylinder not working properly	19
2.3.4. Preventing crushing	20
2.3.5. Risk of injury when drilling holes or screwing	21
2.4. Avoid property damage and functional problems	22
2.5. Qualification of the staff	23
2.6. Layout features of warning notes	24
2.7. Layout features of notes indicating property damage	25
3. Description	26
3.1. Scope of delivery	27
3.1.1. Euro profile	28
3.1.2. Pro MiWE half-cylinder	30
3.1.3. Swiss round profile	31
3.1.4. Scandinavian round profile	32
3.1.5. Scandinavian oval profile	33
3.1.6. Available accessories	34
3.2. Overview of the most important cylinder components	35
3.3. Displays and signals	39
3.4. Knob sleeves	40
3.5. Task and function	41
3.6. The variants' features and functions in detail	42
3.6.1. Double cylinder that reads on one side	43
3.6.2. Double cylinder that has no inner knob and reads on one side	44
3.6.3. Double cylinder that reads on both sides	45
3.6.4. Short / long (SL) cylinder	46
3.6.5. Double cylinder, readable on one side, with slipping clutch	47
3.6.6. Glass door cylinder	48
3.6.7. Half-cylinder	49

3.6.8. Half-cylinder for swivelling lever handles.....	50
3.6.9. Half-cylinder with M4 holes	51
3.6.10. Lever cylinder	52
3.6.11. EE (Emergency Exit) double cylinder that reads on one side.....	53
3.6.12. EE (Emergency Exit) double cylinder that has no inner knob and reads on one side	54
3.6.13. EE (Emergency Exit) double cylinder that has a mechanical inner key and reads on one side	55
3.6.14. Scandinavian round cylinder that reads on one side.....	56
3.6.15. Scandinavian oval cylinder that reads on one side	57
3.6.16. Pro MiWE half-cylinder	58
3.7. Padlock	59
3.8. Technical data.....	60
4. Storing the cylinder.....	61
5. Assembling the cylinder	62
5.1. Preparing for assembly	63
5.1.1. Changing the driver's basic position (Pro MiWE half-cylinder).....	65
5.2. Assembling the double cylinder that reads on one side	67
5.3. Assembling the double cylinder that has a core pulling protection extension (CPPE) and reads on one side	70
5.4. Assembling the double cylinder that has no inner knob and reads on one side.....	75
5.5. Assembling the double cylinder that has no inner knob but does have a core pulling protection extension (CPPE).....	77
5.6. Assembling the double cylinder that reads on both sides.....	81
5.7. Assembling the double cylinder that has a core pulling protection extension (CPPE) and reads on both sides.....	85
5.8. Assembling the short / long (SL) cylinder that reads on one side.....	89
5.9. Assembling the short / long cylinder that has a core pulling protection extension (CPPE) and reads on one side.....	92
5.10. 456.....	97
5.11. 123.....	98
5.12. Assembling the glass door cylinder that reads on one side.....	99
5.13. Assembling the glass door cylinder that has a core pulling protection extension (CPPE) and reads on one side.....	102
5.14. Assembling the EE (Emergency Exit) double cylinder that has an inner knob and reads on one side	107
5.15. Assembling the EE (Emergency Exit) double cylinder that has an inner knob and a core pulling protection extension (CPPE) and reads on one side	112
5.16. Assembling the EE (Emergency Exit) double cylinder that has no inner knob	120
5.17. Assembling the EE (Emergency Exit) double cylinder that has no inner knob but does have a core pulling protection extension (CPPE)	123
5.18. Assembling the EE (Emergency Exit) double cylinder that has a mechanical inner key and reads on one side.....	129
5.19. Assembling the EE (Emergency Exit) double cylinder that has a mechanical key and a core pulling protection extension (CPPE)	132

5.20. Assembling the half-cylinder with M4 holes	138
5.21. Assembling the half-cylinder with a core pulling protection extension (CPPE)	140
5.22. Assembling the half-cylinder with M4 holes	145
5.23. Assembling the half-cylinder for swivelling lever handles	146
5.24. Assembling the lever cylinder	148
5.25. Assembling the Scandinavian round cylinder that reads on one side	152
5.26. Assembling the Scandinavian oval cylinder that reads on one side	153
6. Putting the cylinder into operation	154
6.1. Initialising the cylinder	155
6.2. Creating a transponder	156
7. Maintaining the cylinder	157
7.1. Changing batteries	158
7.1.1. Changing the cylinder's battery pack	160
7.1.2. Changing the padlock's battery pack	164
7.2. Caring for the cylinder	168
8. Dismantling the cylinder	169
9. Disposing of the cylinder	170
10. Contact	171

1. About this manual and manufacturer information

These instructions will help you to securely assemble the PRO digital cylinders in the ENiQ®, ELS® and DOM Tapkey® system families in the Euro profile, Swiss round profile, Scandinavian round profile and Scandinavian oval profile variants. The PRO digital cylinders are hereinafter referred to as 'cylinders' for short, provided that a distinction does not have to be made between the functions.

1.1. Keep the manual available

These instructions form an integral part of the cylinder.

- Keep these instructions with the cylinder.
- Ensure that the instructions are available for the assembly fitter / operator.
- Please include these instructions if you sell the cylinder or pass it on in any other way.



These instructions can be found at www.dom-security.com.

1.2. Text layout features

Various elements of these instructions are provided with defined design features. This makes it easy for you to distinguish between the following elements:

Normal text

- First-level list
- Action steps

 Tips contain additional information for assembly and operation.

1.3. Mutually applicable documents

The following document types are also applicable in particular:

- Data sheets
- Declarations of conformity or installation
- Observe and follow the information contained in the accompanying documents.

1.4. Warranty and liability

Our General Terms and Conditions apply as a matter of principle. Warranty and liability claims that are made if personal injury or property damage occurs are always excluded if they are attributable to one or more of the following causes:

- Improper use of the cylinder
- Failure to observe the notices in these instructions
- Improperly performed assembly
- Improperly performed repairs
- Disasters caused by external influences and force majeure.

1.5. Copyright

This documentation may not be reproduced either in whole or in part, stored or transmitted, disclosed or translated in any form or by any means without the prior written consent of DOM Sicherheitstechnik GmbH & Co. KG.

This documentation is updated at regular intervals. The publisher is always grateful to receive information about any errors or suggestions regarding this documentation.

© DOM Sicherheitstechnik GmbH & Co. KG, Wesselinger Strasse 10–16, 50321 Brühl, Germany

1.6. Documentation Officer

DOM Sicherheitstechnik GmbH & Co. KG
Product Management Department
Wesseling Strasse 10–16
50321 Brühl, Germany

1.7. Manufacturer's address

DOM Sicherheitstechnik GmbH & Co. KG

Wesselinger Straße 10–16

D-50321 Brühl

Phone: +49 (0) 2232 7040

Fax: +49 (0) 2232 704 375

E-mail: dom@dom-group.eu

Internet: www.dom-group.eu

2. Safety and security

2.1. Intended use

The cylinders in the ENiQ, ELS and DOM Tapkey system families can be used in industrial, commercial and private applications.

They are used for access control at doors (e.g. wooden, metal, plastic and glass doors) in buildings. The system families are based on RFID (radio frequency identification) technology and differ in terms of the frequency used. ENiQ and DOM Tapkey use 13.56 MHz, while ELS uses 125 kHz.

The cylinders can also be used on escape and rescue doors according to EN 179 and EN 1125.

Functional reliability can only be guaranteed when the cylinders are installed in escape door systems that comply with the EN 179 (emergency exit locks) and EN 1125 (panic door locks) standards. Before installation, it is therefore imperative to check whether the cylinder in question is appropriately compatible with the lock being used. For compatibility, please refer to DOM Sicherheitstechnik GmbH & Co. KG's compatibility list, the lock manufacturer's compatibility list or the lock's relevant certificate. In case of doubt, the lock manufacturer's statement applies.

For VdS-compliant assembly, all variants of cylinders must be protected with a burglary-resistant Class B and C door plate. Such door plates comply with DIN 18257 Class ES2-ZA or ES3-ZA.

For installation in compliance with EN 15684, other necessary components may have to be adapted to ensure conformity with this European standard.

Before all variants of cylinders are assembled in a fire-proof / smoke-proof door, the fire certification must be checked to ensure conformity.

Proper use includes reading and understanding these instructions as well as observing and following all the information provided in these instructions, particularly the safety notices. Furthermore, all relevant standards must be observed and followed.

Any other use is expressly considered to be improper.

2.2. Ambient conditions

Ensure that the PRO digital cylinders are only used under the following ambient conditions:

- Temperature range: -25 °C to $+65\text{ °C}$
- Air humidity: 20% to 99% (non-condensing)

2.3. Fundamental safety information

The cylinders are built according to the state of the art and the recognised safety regulations. When working with and on the cylinder, however, residual risks that can cause danger to life and limb remain. The following safety notices must therefore be observed and followed.

2.3.1. Avoid risks of explosion

The cylinders are not explosion-proof.

- Assemble and operate the cylinders and the padlock only in areas where there is no potentially explosive atmosphere.

2.3.2. Preventing risk of injury due to swallowing small parts

Children can become injured after swallowing small parts.

- Make sure that small parts e.g. locking media or screws are kept out of the reach of children.

2.3.3. Preventing serious injury or death caused by an EE (Emergency Exit) cylinder not working properly

- Have the EE (Emergency Exit) cylinder assembled by qualified personnel only.
- Maintain worn locks; replace them if necessary.
- Maintain live doors (jamming doors); readjust them if necessary.
- Before assembling the EE (Emergency Exit) cylinder, ensure that the doors and locks are properly installed and are not warped.
- Ensure that the knobs are easy to move following installation and do not rub against the handle.
- Following assembly, check whether the escape door system is working properly.
- Ensure that the escape door can swing open unhindered once the EE (Emergency Exit) cylinder is assembled.
- Ensure that the assembly of the EE (Emergency Exit) cylinder does not obscure or destroy any warning signs or pictograms. If necessary, replace the warning signs or pictograms or have them assembled in a different position.
- Perform functional testing after each assembly process. The inner knob of the EE (Emergency Exit) cylinder must always return to the neutral position by its own force after twisting. If you are using an EE (Emergency Exit) cylinder without an inner knob, you must check it when it is engaged using the electronic knob.
- Straight after assembly, check whether the escape door and panic lock can be opened in a single movement with the cylinder in any position (0–360°).
- Observe and follow the applicable DIN or EN standards.
- Have the maintenance work carried out by qualified personnel.
- Additionally, always observe and follow the maintenance instructions issued by the door, lock and handle manufacturers.
- Ensure that the maintenance intervals specified by the door, lock and handle manufacturers are always observed.
- Replace the EE (Emergency Exit) cylinder on escape and rescue doors once the maximum number of closing cycles specified on the data sheet has been reached.
- If you use the Pro MiWE half-cylinder, check the driver's basic position before assembly. It is in the 6 o'clock position when delivered. If necessary, change the driver's basic position to the basic position required for your application (see the section Preparing for assembly from page 28 onwards). The driver is automatically returned to the set basic position once the closing process is complete.

2.3.4. Preventing crushing

Fingers may be crushed when assembling the cylinder.

- Always ensure that there is enough space between your fingers and the door frame.

2.3.5. Risk of injury when drilling holes or screwing

Risk of eye injuries due to flying drilling dust or chips.

- Wear safety goggles.
- Use a device to extract the drilling dust or chips.
Risk of finger or hand injuries caused by slipping during drilling or screwing work.
- Wear suitable safety gloves.
- Observe and follow the notices provided in the drilling machine documentation.
Risk of finger or hand injuries caused by slipping during screwing work.
- Wear suitable safety gloves.

2.4. Avoid property damage and functional problems

Preventing property damage caused by incorrect storage for an extended period of time

- Store the device and its components in their original packaging in a dry and dust-free place.
Preventing property damage caused by improper assembly and operation
- Read these instructions carefully before assembling and commissioning the device.
- Follow the instructions one step at a time.
- Secure the screws according to the information provided in these instructions.
Preventing property damage caused by improper use
- Never throw or drop the cylinder.
- Always use the door handle or lever handle, not the cylinder's electronic knob, to close the door.
Preventing property damage caused by stiff locks or jamming doors
- Maintain the worn locks; replace them with new ones if necessary.
- Maintain live doors (jamming doors).
Preventing property damage caused by incorrect maintenance
- Do not use oil, grease or acid on the cylinder.
- Ensure that no moisture gets into the cylinder during maintenance.
Preventing property damage caused by electrostatic discharge.
- Before dismantling / assembling the knob sleeve, prevent electrostatic charges or touch a conductive, earthed object (e.g. a water pipe or heater) to electrostatically discharge yourself.
- Never touch electronic components with your fingers.
The date and time may be lost once the batteries are changed.
The date and time being lost can interfere with / block correct use of permissions with schedules.
- After changing batteries, use the app or software to check whether the date and time are still up-to-date.
- Correct the date and time if necessary.
Reduced range possible due to metallic objects in the immediate vicinity of the cylinder or padlock.
- Ensure that there are no metallic objects in the immediate vicinity of the cylinder or padlock.
Malfunction caused by two readers influencing one another.
If the distance is too short, an authorised closing device can be delayed or remain undetected.
- Assemble the cylinders at least 50 cm apart from one another.
Malfunction caused by external systems being present.
External systems can emit interference fields. This can delay an authorised closing device or make it unrecognisable, in addition to hindering or preventing programming of the device.
- Ensure that external systems do not influence the cylinders and the padlock.
Malfunction caused by other manufacturers' products being used.
- When changing batteries, only use the manufacturer's batteries.

2.5. Qualification of the staff

People working on and with the cylinder must have basic manual skills and basic knowledge of how to use RFID systems to meet the following requirements:

- Capable of safely drilling holes and screw connections,
- Capable of understanding how the cylinder works and how the individual components interact.

2.6. Layout features of warning notes

! Notices containing the word **WARNING** indicate a dangerous situation that could potentially result in death or serious injury.

! Notices with the word **CAUTION** warn of a situation which can lead to light or moderate injuries.

2.7. Layout features of notes indicating property damage

* These notes warn about situations that lead to property damage.

3. Description

3.1. Scope of delivery

Depending on the variant or order, the following may be included in the scope of delivery:

3.1.1. Euro profile

Double cylinder that reads on one side

- Core pulling protection extension (8.5 mm), if necessary
- 1 × fixing screw
- Batteries (pre-assembled), 1 × pack of 2 CR2 batteries

Double cylinder that reads on both sides

- Core pulling protection extension (8.5 mm), if necessary
- 1 × fixing screw
- Batteries (pre-assembled once), 2 × pack of 2 CR2 batteries

Double cylinder that has no inner knob

- Core pulling protection extension (8.5 mm), if necessary
- 1 × fixing screw
- Batteries (pre-assembled), 1 × pack of 2 CR2 batteries

EE (Emergency Exit) double cylinder that reads on one side

- Core pulling protection extension (8.5 mm), if necessary
- 1 × fixing screw
- Batteries (pre-assembled), 1 × pack of 2 CR2 batteries

EE (Emergency Exit) double cylinder that has no inner knob and reads on one side

- Core pulling protection extension (8.5 mm), if necessary
- 1 × fixing screw
- Batteries (pre-assembled), 1 × pack of 2 CR2 batteries

EE (Emergency Exit) double cylinder that has a mechanical inner key and reads on one side

- Core pulling protection extension (8.5 mm), if necessary
- 1 × fixing screw
- Batteries (pre-assembled), 1 × pack of 2 CR2 batteries

Double cylinder, readable on one side, with slipping clutch

- Core pulling protection extension (8.5 mm), if necessary
- 1 × fixing screw
- Batteries (pre-assembled), 1 × pack of 2 CR2 batteries

Short / long (SL) cylinder

- Core pulling protection extension (8.5 mm), if necessary

- 1 × fixing screw
- Batteries (pre-assembled), 1 × pack of 2 CR2 batteries

Glass door cylinder

- Core pulling protection extension (8.5 mm), if necessary
- 1 × fixing screw
- Batteries (pre-assembled), 1 × pack of 2 CR2 batteries

Half-cylinder

- Core pulling protection extension if necessary
- 1 × fixing screw
- Battery pack (pre-assembled), 1 × pack of 2 CR2 batteries

Half-cylinder for swivelling lever handles

- 1 × fixing screw
- Battery pack (pre-assembled), 1 × pack of 2 CR2 batteries

Half-cylinder with M4 fixing holes

- 1 × M4 × 12 screw
- Battery pack (pre-assembled), 1 × pack of 2 CR2 batteries

Lever cylinder

- 1 × hexagon nut (WAF 30)
- 2 × hexagon nut (WAF 14)
- 1 × lever travel limiter
- 1 × lever
- Batteries (pre-assembled), 1 × pack of 2 CR2 batteries

Padlock

- Battery pack (pre-assembled), 1 × pack of 2 CR2 batteries

3.1.2. Pro MiWE half-cylinder

- 1 x fixing screw
- Battery pack (pre-assembled), 1 × pack of 2 CR2 batteries

3.1.3. Swiss round profile

The following cylinders are available in the Swiss round profile variant:

- Double cylinder that reads on one side
- Double cylinder that reads on both sides
- Double cylinder that has no inner knob
- Double cylinder, readable on one side, with slipping clutch
- Glass door cylinder
- Short / long (SL) cylinder
- Half-cylinder
- Half-cylinder Pro MiWE
- EE (Emergency Exit) double cylinder that has an inner knob and reads on one side
- EE (Emergency Exit) double cylinder that has no inner knob

The scope of delivery, functional description and assembly in the Euro and Swiss round profiles are the same.

3.1.4. Scandinavian round profile

Outer cylinder that reads on one side

- Batteries (pre-assembled) 1 × pack of 2 CR2 batteries

A mechanical inner cylinder is required for assembling the outer cylinder. It is not included in the scope of delivery.

3.1.5. Scandinavian oval profile

Outer cylinder that reads on one side

- Batteries (pre-assembled), 1 × pack of 2 CR2 batteries

A mechanical inner cylinder is required for assembling the outer cylinder. It is not included in the scope of delivery.

3.1.6. Available accessories

The following accessories are available as options:

- Master card, programming card, RF wake-up card, RF online card, battery change card, service maintenance card, permanently open card, permanently closed card in the ISO credit card format
- Knob tool
- Fixing bracket
- Battery pack
- Special EE IM key
- TORX screwdriver (T6)
- TORX screwdriver (T10) for removing the padlock cover
- Transponders in various designs (tag, ISO card, clip tag, etc.)
- Tapkey app (DOM Tapkey family only)
- ENiQ app (ENiQ family only)
- 'ENiQ Access Management' or 'ELS software and/or ELSmobile software' for PC or laptop
- USB 868 MHz wireless stick
- USB BLE 2.4 GHz wireless stick
- PC desktop reader for reading and writing closing devices in software
- ENiQ EasyFlex Booklet (for the ENiQ family only)

Please refer to the current price list for other accessories.

3.2. Overview of the most important cylinder components

p(banner tip).The following figures are schematic diagrams. The cylinders may look different in detail.

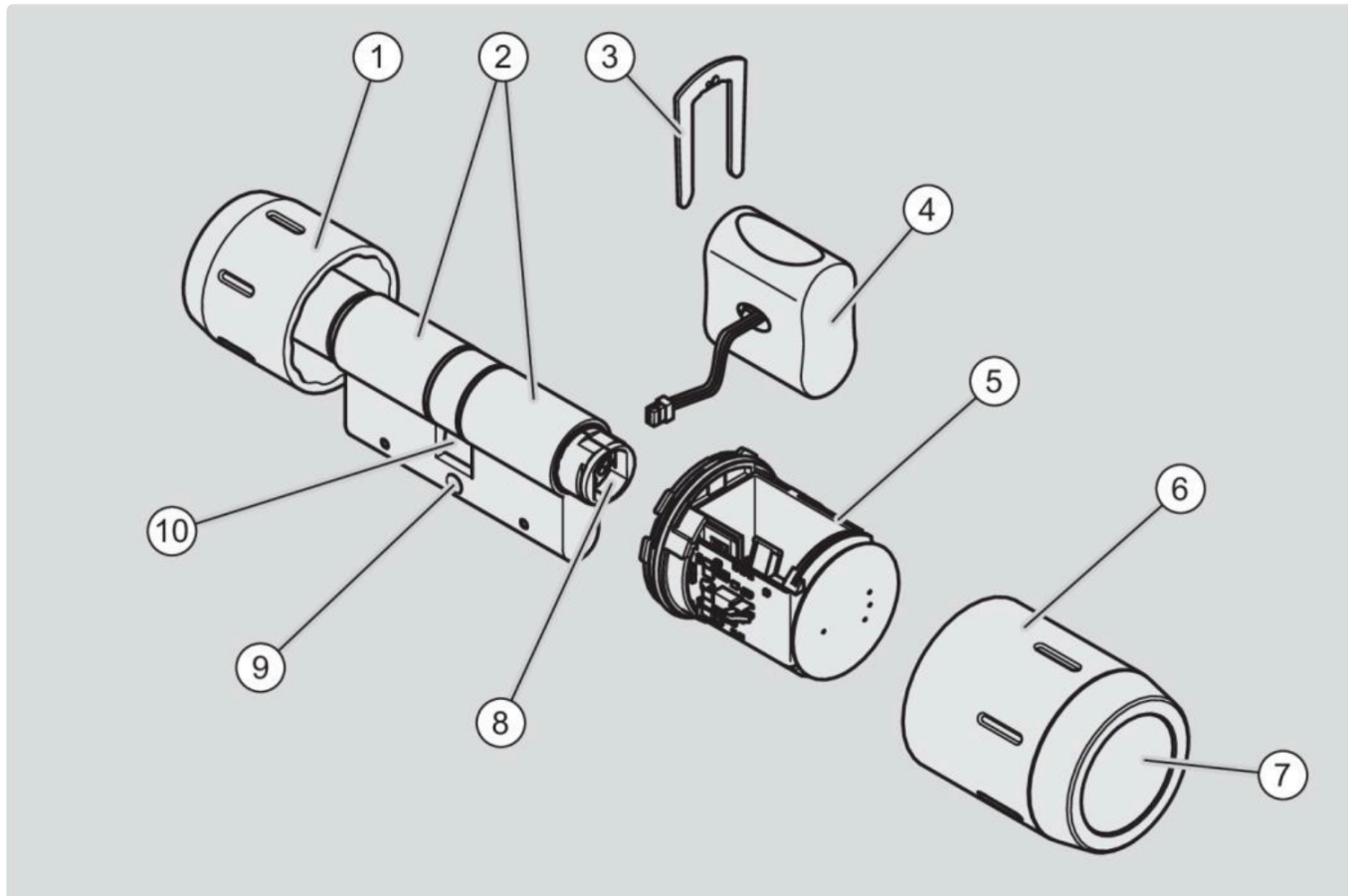

Fig. 1: Overview of the components of the double cylinder that reads on one side

No.	Designation	Notes
1	Inner knob (mechanical)	Inside Knob K6 (Variant “with slipping clutch”)
2	Cylinder body	
3	Fixing bracket	
4	Battery pack (pack of 2 CR2 batteries)	
5	Electronic knob	
6	Knob sleeve	
7	Reading field cover with illuminated ring	
8	Coupling shaft	
9	Thread for securing the cylinder	
10	Locking nose	

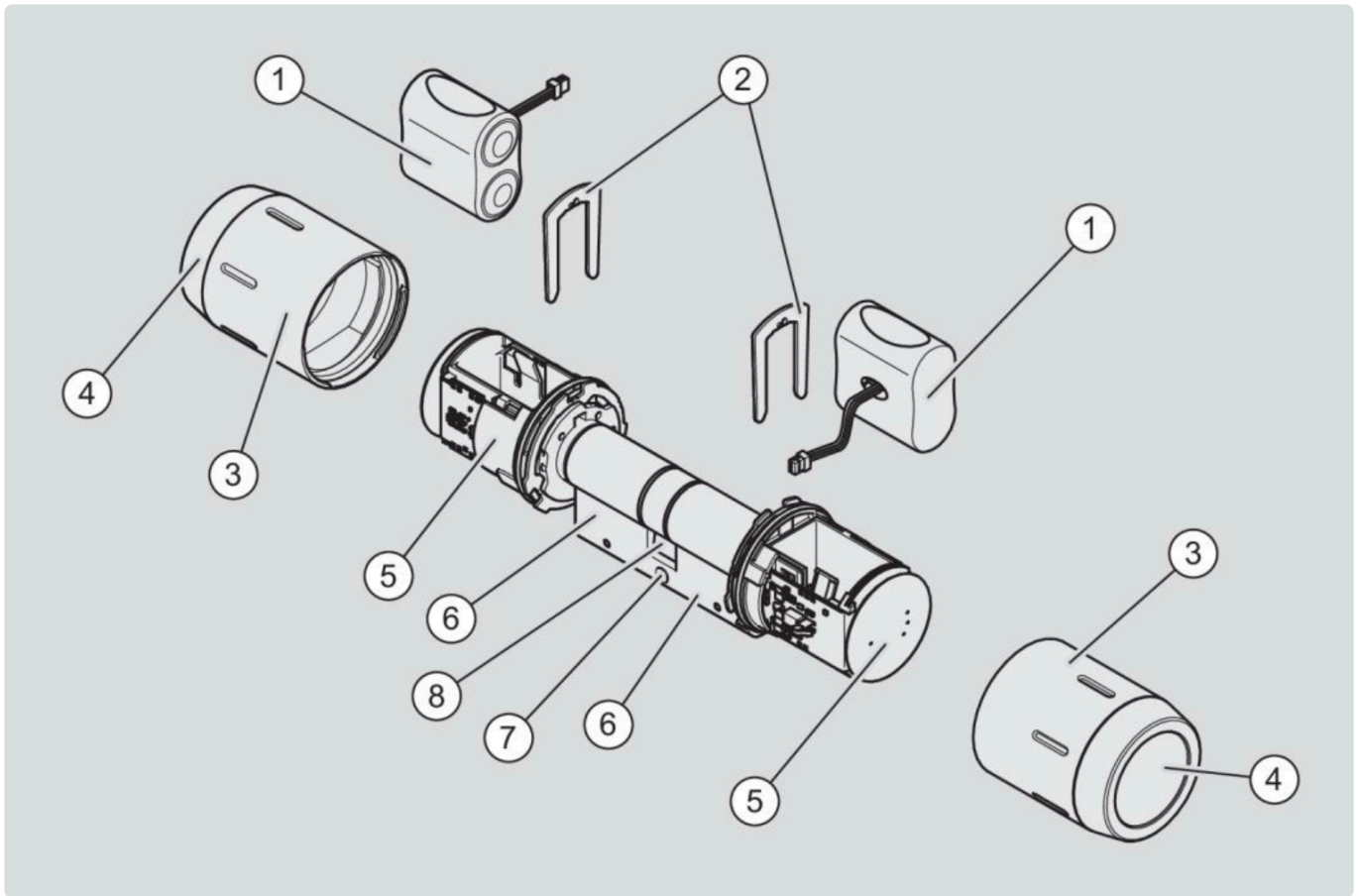

Fig. 2: Overview of the components of the double cylinder that reads on both sides

No.	Designation
1	Battery pack (pack of 2 CR2 batteries)
2	Fixing bracket
3	Knob sleeve
4	Reading field cover with illuminated ring
5	Electronic knob
6	Cylinder body
7	Thread for securing the cylinder
8	Locking nose

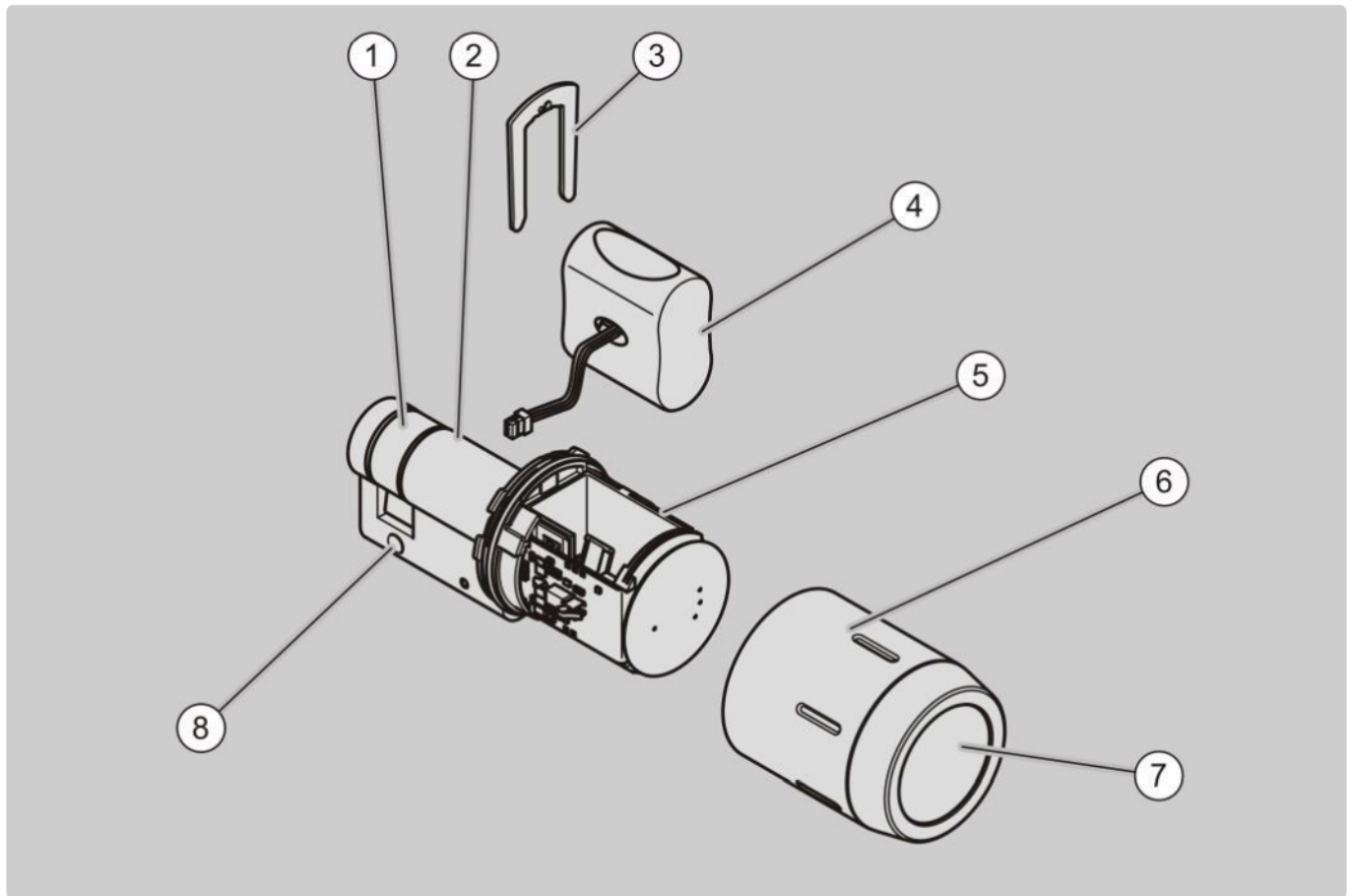

Fig. 3: Overview of the half-cylinder's components

No.	Designation
1	Locking nose
2	Cylinder body
3	Fixing bracket
4	Battery pack (pack of 2 CR2 batteries)
5	Electronic knob
6	Knob sleeve
7	Reading field cover with illuminated ring
8	Thread for securing the cylinder using the fixing screw

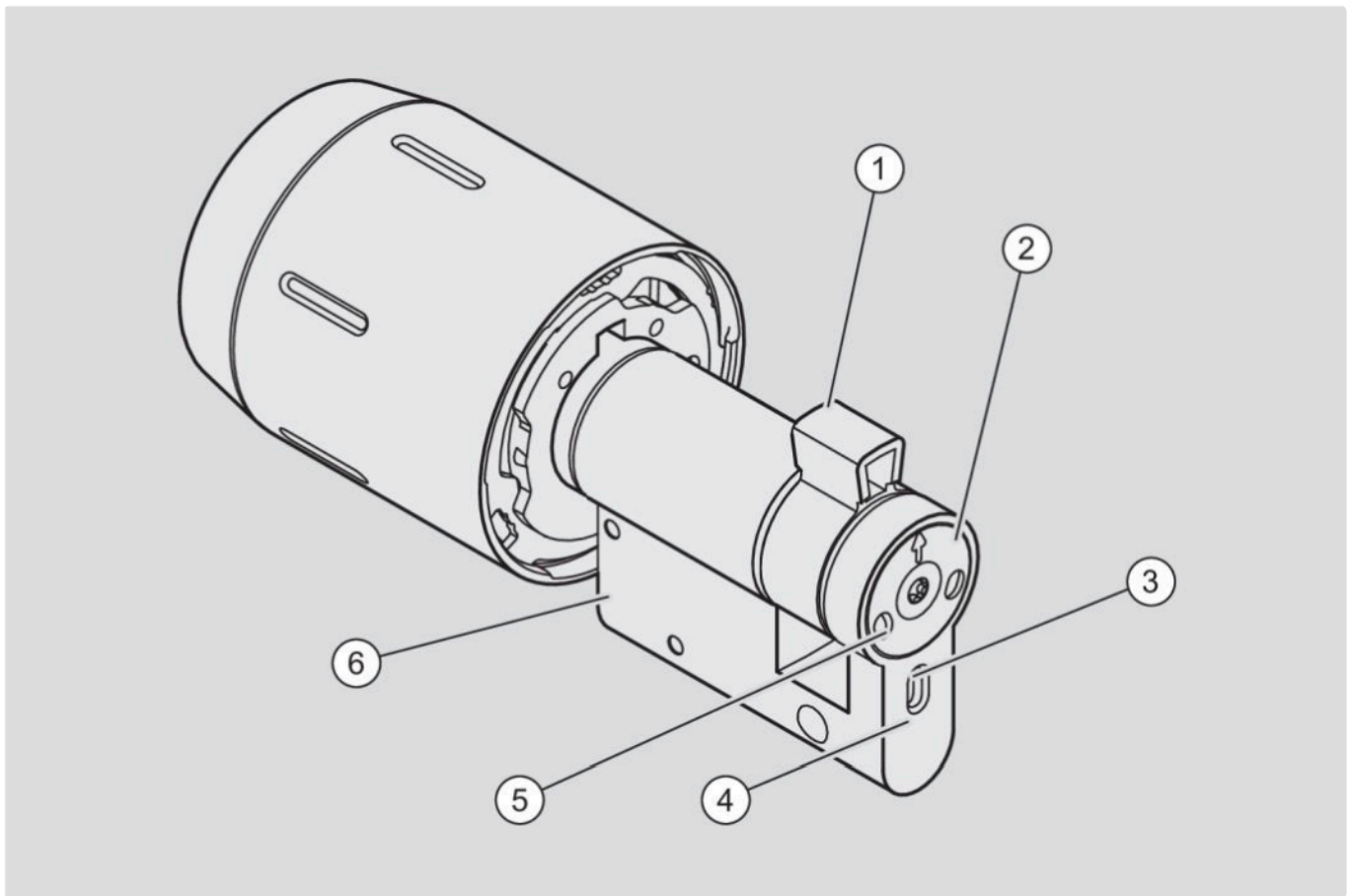

Fig. 4: Overview of the Pro MiWE half-cylinder's components

No.	Designation
1	Driver
2	Clamping disc
3	Latch pin groove
4	Latch pin
5	Inspection window for the return spring
6	Cylinder body

3.3. Displays and signals

LEDs are positioned behind each cylinder's reading field and the padlock's half-cylinder. The LEDs can individually, consecutively or simultaneously light up in different colours. This is how the LEDs indicate permissions, operating states and errors.

Notices relating to the signals and the corresponding device states can be found in the separate instructions entitled 'Device functions, states and signalling'.

The following colours are possible:

- Green
- Yellow
- Red
- Blue
- White
- Magenta
- Cyan

3.4. Knob sleeves

The knob sleeves are available in the following colours:

- Brass
- High-gloss black
- High-gloss white.

3.5. Task and function

The cylinders of the ENiQ, ELS and DOM Tapkey system families are used for access control on doors (e.g. wooden, metal, plastic and glass doors) in buildings. The system families are based on RFID (radio frequency identification) technology and differ in terms of the frequency used. ENiQ and DOM Tapkey use 13.56 MHz. ELS uses 125 kHz.

The cylinders can also be used on escape and rescue doors according to EN 179 and EN 1125.

Functional reliability can only be guaranteed when the cylinders are installed in escape door systems that comply with the EN 179 (emergency exit locks) and EN 1125 (panic door locks) standards.

The cylinders can be equipped with a core pulling protection extension (CPPE). The core pulling protection rosette or the core pulling protection handle are a safety device. They prevent the cylinder core from being pulled out with a special tool. The core pulling protection extension is an extension of the outer knob shaft that enables the cylinder to be guided through a core pulling protection rosette or core pulling protection with a greater wall thickness and the outer electronic knob does not rub against the core pulling protection rosette / handle following assembly.

The power supply for the cylinder and the half-cylinder in the padlock is provided by a battery pack (pack of 2 CR2 batteries).

Most cylinders are splash-proof to IP65.

The electronic knob on digital cylinders is only released if a transponder with a relevant permission (an authorised transponder) is held against the reading field. Data is transmitted inductively (via RFID) between the transponder and the reading field by means of a coil that is present in the cylinder's electronic knob and in the transponder. The cylinder's electronic knob is battery-powered to guarantee its function. The transponder does not require a power source.

3.6. The variants' features and functions in detail

3.6.1. Double cylinder that reads on one side

The double cylinder can be assembled in doors. It has a reading field on one side. It controls access from the outside. Only people with an appropriately authorised transponder can operate the outer electronic knob and open the door from the outside.

The door can be opened mechanically from the inside with the inner knob.

The double cylinder can also be supplied with a core pulling protection extension (CPPE).

3.6.2. Double cylinder that has no inner knob and reads on one side

The double cylinder that has no inner knob can be assembled in doors. It has a reading field on one side. It controls access from the outside. Only people with an appropriately authorised transponder can operate the electronic knob and open the door from the outside. The door cannot be locked from the inside with this cylinder.

The double cylinder that has no inner knob can also be supplied with a core pulling protection extension (CPPE).

3.6.3. Double cylinder that reads on both sides

The double cylinder can be assembled in doors. It has two reading fields. It controls access from both sides. Only people with an appropriately authorised transponder can operate the electronic knobs and open the door from both sides if necessary.

Flows of people can be controlled specifically by one object or areas can be clearly separated from one another by assigning different permissions on the outside and inside.

The double cylinder can also be supplied with a core pulling protection extension (CPPE).

3.6.4. Short / long (SL) cylinder

The short / long cylinder can be installed in doors with a protruding fold. It has a reading field on one side. It controls access from the outside. Only people with an appropriately authorised transponder can operate the electronic knob and open the door. The door can be opened mechanically from the inside using the inner knob.

The short / long cylinder can also be supplied with a core pulling protection extension (CPPE).

3.6.5. Double cylinder, readable on one side, with slipping clutch

The double cylinder can be mounted in doors. It has a reading field on one side. It regulates access from the outside. Only persons with an appropriately authorized transponder can operate the outer electronic knob and open the door from the outside.

The door can be opened mechanically from the inside with the inner knob. The double cylinder can also be supplied with a core pulling protection extension (KZSV).

The inside knob cannot be operated when the outside knob is engaged and locked. In this state, the inside spindle slips when the inside knob is turned.

3.6.6. Glass door cylinder

The glass door cylinder is assembled in a glass door with handle. The glass door cylinder has a reading field on one side. It controls access from the outside. Only people with an appropriately authorised transponder can operate the electronic knob and open the door. The door can be operated from the inside using the inner knob.

The glass door cylinder can also be supplied as a core pulling protection extension (CPPE).

3.6.7. Half-cylinder

The half-cylinder can be assembled in key switches, gates, distribution cabinets, etc. It has a reading field on one side. It controls access from the outside. Only people with an appropriately authorised transponder can operate the electronic knob and open the key switches, gates, distribution cabinets, etc. The half-cylinder can also be supplied with a core pulling protection extension (CPPE).

3.6.8. Half-cylinder for swivelling lever handles

The half-cylinder is assembled in swivel lever handles. It has a reading field on one side. It controls access from the outside. Only people with an appropriately authorised transponder can operate the electronic knob and operate the swivel lever handle e.g. on a server cabinet.

3.6.9. Half-cylinder with M4 holes

The M4 half-cylinder can be installed in a lift control panel. It has a reading field on one side. It controls access from the outside. Only people with an appropriately authorised transponder can operate the electronic knob and activate the lift control board, select the corresponding floor or set the priority circuit.

3.6.10. Lever cylinder

The lever cylinder can be installed in letterboxes, for example. It has a reading field on one side. It controls access from the outside. Only people with an appropriately authorised transponder can operate the reading knob and open the letterbox.

3.6.11. EE (Emergency Exit) double cylinder that reads on one side

The EE (Emergency Exit) double cylinder can be installed in escape door systems that comply with the EN 179 (emergency exit locks) and EN 1125 (panic door locks) standards.

With this cylinder, the locking nose is moved to a defined position (6 o'clock position) when the cylinder is idle, so that the anti-panic function can be used at any time. Before the cylinder is installed, it must be ensured that the anti-panic function is guaranteed.

The EE (Emergency Exit) double cylinder has a reading field on one side. It controls access from the outside. Only people with an appropriately authorised transponder can operate the electronic knob and open the door. The door can be opened at any time from the inside using the inner knob.

The EE (Emergency Exit) double cylinder can also be supplied with a core pulling protection extension (CPPE).

3.6.12. EE (Emergency Exit) double cylinder that has no inner knob and reads on one side

The EE (Emergency Exit) double cylinder can be installed in escape door systems that comply with the EN 179 (emergency exit locks) or EN 1125 (panic door locks) standards.

With this cylinder, the locking nose is moved to a defined position (6 o'clock position) when the cylinder is idle, so that the anti-panic function can be used at any time. Before the cylinder is installed, it must be ensured that the anti-panic function is guaranteed

The EE (Emergency Exit) double cylinder has a reading field on one side. It controls access from the outside. Only people with an appropriately authorised transponder can operate the electronic knob and open the door. The door can be opened at any time using the lever handle or panic bar. The door cannot be locked from the inside with this cylinder.

The EE (Emergency Exit) double cylinder can also be supplied with a core pulling protection extension (CPPE).

3.6.13. EE (Emergency Exit) double cylinder that has a mechanical inner key and reads on one side

The EE (Emergency Exit) double cylinder can be installed in escape door systems that comply with the EN 179 (emergency exit locks) and EN 1125 (panic door locks) standards.

With this cylinder, the locking nose is moved to a defined position (6 o'clock position) when the cylinder is idle, so that the anti-panic function can be used at any time. Before the cylinder is installed, it must be ensured that the anti-panic function is guaranteed.

The EE (Emergency Exit) double cylinder has a reading field on one side. It controls access from the outside. Only people with an appropriately authorised transponder can operate the electronic knob and open the door. The door can be opened at any time from the inside or locked with a special key.

The EE (Emergency Exit) double cylinder can also be supplied with a core pulling protection extension (CPPE).

3.6.14. Scandinavian round cylinder that reads on one side

The round cylinder is assembled in doors on the outside. It has a reading field on one side. It controls access from the outside. Only people with an appropriately authorised transponder can operate the electronic knob and open the door. The door can be opened mechanically from the inside using the inner knob or key. The mechanical inner cylinder is not provided by DOM.

3.6.15. Scandinavian oval cylinder that reads on one side

The oval cylinder is assembled in doors on the outside. It has a reading field on one side. It controls access from the outside. Only people with an appropriately authorised transponder can operate the electronic knob and open the door. The door can be opened mechanically from the inside using the inner knob or key. The mechanical inner cylinder is not provided by DOM.

3.6.16. Pro MiWE half-cylinder

The PRO MiWE half-cylinder is a freewheeling cylinder, but with limited and adjustable driver travel (MiWE). It can be used with all electronics of the PRO systems (ENiQ, ELS, Tapkey).

The actuating direction (direction of rotation) is available in a clockwise or anti-clockwise version as an option (when looking at the knob).

The driver's basic position can be set to 8 different positions (increments of 45°). It is in the 6 o'clock position when delivered.

Once the closing process (disengagement) is complete, the driver is returned to and held in the set basic position by spring force.

3.7. Padlock

The padlock can be attached to gates, cabinets, lockers, tool boxes, etc., that have an eyelet lock. It has a reading field on one side. Only people with an appropriately authorised transponder can operate the electronic knob and open the padlock's shackle.

3.8. Technical data

p(banner tip). The current technical instructions and product information can be found on the website at www.dom-security.com.

4. Storing the cylinder

Proceed as follows to store the cylinder for an extended period of time before assembly or after use:

- Store the cylinder in its original packaging in a dry and dust-free place and at room temperature.
- Store the cylinder, and particularly its electronics, at least 15 cm away from metallic objects, transponder coils and card coils.

5. Assembling the cylinder

5.1. Preparing for assembly

Cylinder assembly differs depending on the variant. Proceed as follows in principle for assembly:

- Remove the cylinder from the packaging.
- Keep the original packaging so that you can store the cylinder in a protected state at any time or for a possible return.
- Check that all parts are complete and in perfect condition.
- If necessary, provide the required tool with additional material.
- Dismantle the existing cylinder if necessary and prepare the door for assembly.

For assembling the cylinder in a core pulling protection handle, security handle or rosette, prepare the handle or rosette so that the cylinder's coupling shaft fits through the handle's opening. Due to the large number of handles and rosettes available on the market, the individual handles and rosettes are not shown here, and dismantling is not explained. Please note whether the cylinder is used in a core pulling protection handle / rosette when ordering and order the cylinder in a CPPE design if necessary.

- Check that the cylinder is working properly.
- Ensure that the door is hinged properly.
- Ensure that the door is not warped.
- Ensure that the door is not under strain.
- Ensure that the door design allows the cylinder to be installed.
- Ensure that the door lock provides an appropriate profile perforation for the cylinder and screwing option. Replace the lock if necessary

Check the following points in particular:

- Is / are any drilling dust or chips produced cleanly removed during drilling?
- Has the cylinder perforation in the lock been neatly calibrated with the perforation in the door?
- If necessary, ensure that all these points are met by reworking.

You require the following tools:

- Knob tool for assembling the electronic outer knob if it is not pre-assembled and for loosening the electronic knob's knob sleeve for a battery change
- TORX screwdriver (T6) for assembling a mechanical inner knob
- If necessary, a fixing bracket for removing the inserted fixing bracket when dismantling an electronic knob
- Phillips screwdriver for the fixing screw
- TORX screwdriver (T10) for dismantling the padlock cover to change the batteries

The tools are not included in the scope of delivery unless explicitly described (e.g. for DOM Tapkey and EasyFlex).

 If you want to assemble a large number of digital cylinders, we recommend that you carry out the initialisation process before assembly (see page 110 onwards regarding this matter). If you want to program with a master card, programming card or software, you can also create programming and closing devices before assembling the cylinder.

 For cylinders that read on both sides, it is advisable to only initialise the knob electronics

that have already been assembled. The second knob electronics should only be initialised once the entire cylinder has been assembled, since the outer knob electronics would have to be dismantled before assembly.

- ✿ Assembly of the cylinders in the Euro profile, Swiss round profile, Scandinavian round profile and Scandinavian oval profile variants is described in the sections below. Assembling Swiss round profile cylinders is the same as assembling Euro profile cylinders and is not described separately below.

5.1.1. Changing the driver's basic position (Pro MiWE half-cylinder)

You can change the driver's basic position before installing the PRO MiWE half-cylinder. You may have to change the driver's basic position after installation depending on the application or installation situation. As an alignment aid, the arrow on the face of the clamping disc indicates the driver's position.

Delivery state

Driver position

The driver is usually in the 6 o'clock position when delivered.

The arrow (1) on the face of the clamping disc indicates the driver's basic position when the driver is not actuated.

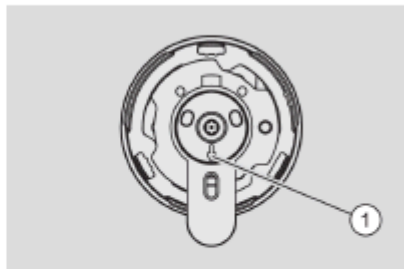

Fig. 5: Driver in the 6 o'clock position

A different position can be set if desired. The following eight positions are possible in increments of 45° (when looking at the knob):

12.00 o'clock, 10.30 o'clock,
9.00 o'clock, 7.30 o'clock,
6.00 o'clock, 4.30 o'clock,
3.00 o'clock, 1.30 o'clock)



Fig. 6: Possible driver positions

Actuating direction

The Pro MiWE is available ex works with two actuating directions:

- Right / clockwise rotation (when looking at the knob): The spring is visible in the clamping disc's left inspection window.

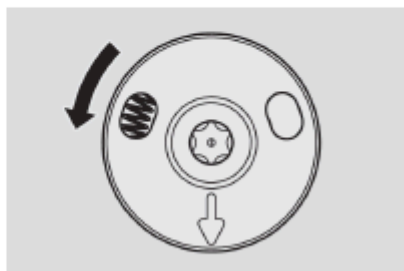

Fig. 7: Right actuating direction

- **Left / anti-clockwise rotation** (when looking at the knob): The spring is visible in the clamping disc's right inspection window.

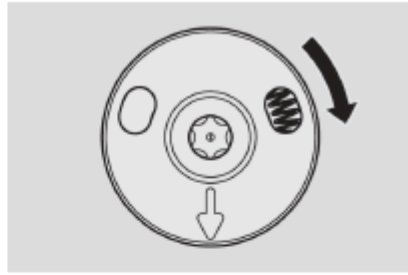

Fig. 8: Left actuating direction

Adjusting the driver's basic position

Proceed as follows to change the driver's basic position:

- ▶ Check the driver's position and the actuating direction (see the section entitled 'Delivery state').
- ▶ Insert the release needle (1) or a small slotted screwdriver through the slot (3) on the face of the cylinder body (4) into the latch pin groove (1.).
- ▶ Press down the latch pin (2) with the release needle (1) against the spring force (2.).
- ▶ Turn the driver (5) against the actuating direction and into the desired basic position (3.).
- ▶ Pull the release needle (1) or slotted screwdriver out of the latch pin groove to release (4.) the latch pin (2).

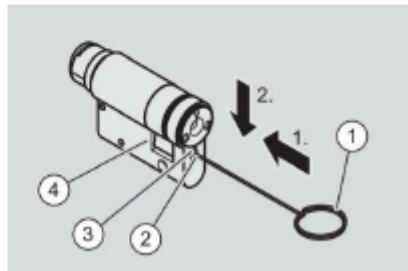

Fig. 9: Unlocking the driver

The latch pin engages by spring force.

If the latch pin does not engage, turn the driver (5) back and forth minimally until the latch pin engages.

- ▶ Check the basic position, working position and spring return.

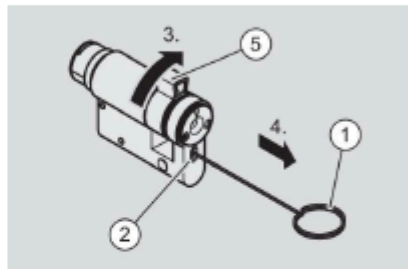

Fig. 10: Engaging the driver

5.2. Assembling the double cylinder that reads on one side

* The cylinder that reads on one side is usually assembled from the outside. If assembly from the inside is necessary, proceed in reverse order to assemble an electronic knob, as described in the section entitled Double cylinder that reads on both sides from page 45 onwards.

* Always assemble the cylinder with the door open so that you do not lock yourself out. The electronic knobs are engaged before initialisation when they are delivered and the cylinder's locking nose can thus be rotated.

* The following figures are schematic diagrams.

Proceed as follows to assemble the double cylinder:

- Measure the door's thickness with the handle.
- Ensure that the cylinder's basic length is adapted to the measured thickness. Note the division into outside (a) and inside (b) in this regard.

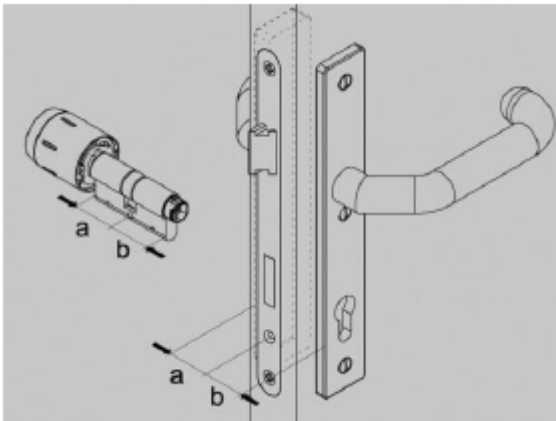

Fig. 11: Measuring the thickness

! If the cylinder protrudes more than 3 mm from the handles and rosettes, burglary protection can no longer be guaranteed.

- Always ensure that the cylinder protrudes max. 3 mm from the handles and rosettes.
- Position the locking nose (3) so that it is flush with the cylinder body (2).
- Carefully slide the double cylinder (1) through the handle, door and lock from the outside.

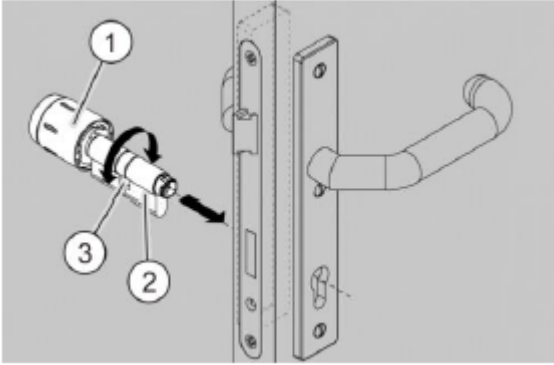

Fig. 12: Inserting the cylinder

! Damage to the cylinder caused by tightening the fixing screw or lock with a cordless screwdriver without torque limitation.

- Tighten the fixing screw with a Phillips screwdriver only so that it is hand-tight.
- Turn the already assembled rotary knob or special key and pull the cylinder (1) forwards and backwards until you have felt the correct locking nose position to drive out the lock's bolt (5).
- Leave the bolt (5) extended until the fixing screw is completely screwed into the cylinder.
- Secure the double cylinder with the fixing screw (4). Do not fully tighten the fixing screw (4) yet.

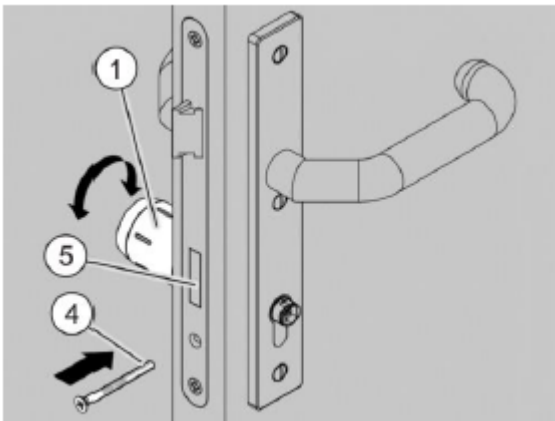

Fig. 13: Aligning the locking nose

- Precisely fit the inner knob (6) onto the cylinder's (1) coupling shaft as far as it will go. The inner knob (6) can only be fitted in one position.

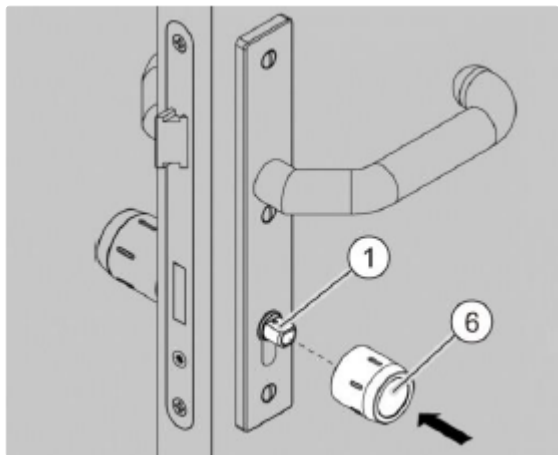

Fig. 14: Fitting the inner knob

- If necessary, turn the inner knob (6) with the coupling shaft so that the set screw (7) is easily accessible for the screwdriver.
- Tighten the M3 set screw (7) in a clockwise direction with a TORX screwdriver (T6) so that it is hand-tight (approx. 4 turns).
- Ensure that the inner knob and electronic knob can be turned freely without rubbing against the handle.
- Tighten the fixing screw (4) with a Phillips screwdriver so that it is hand-tight.

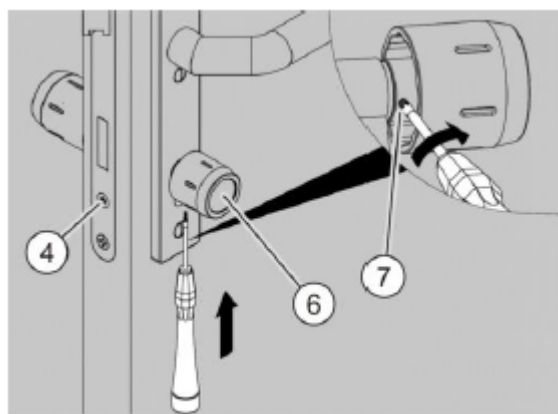

Fig. 15: Securing the inner knob

5.3. Assembling the double cylinder that has a core pulling protection extension (CPPE) and reads on one side

* The following describes the assembly process for protective handles or for rosettes with round holes, for which the core cover usually has to be removed before assembly. Due to the large number of handles and rosettes available on the market, the individual handles and rosettes are not shown here, and dismantling of the core cover is not described.

* The following figures are schematic diagrams.

Proceed as follows to assemble the double cylinder:

- Measure the door's thickness with the handle.
- Ensure that the cylinder's basic length is adapted to the measured thickness. Note the division into outside (a) and inside (b) in this regard.

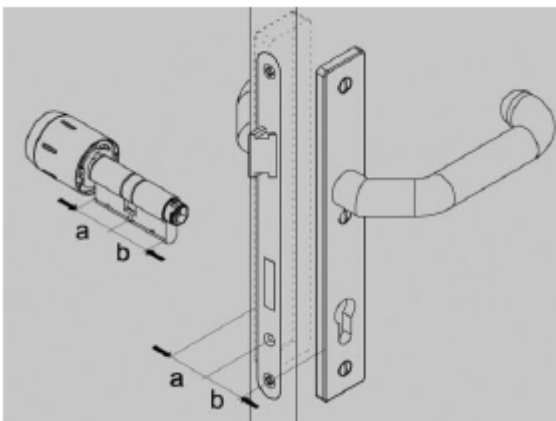

Fig. 16: Measuring the thickness

* The cylinder with the core pulling protection extension must be inserted into the installation hole from the inside to the outside. The side with the core pulling protection extension should be on the outside.

* Always assemble the cylinder with the door open so that you do not lock yourself out. The electronic knobs are engaged before initialisation when they are delivered and the cylinder's locking nose can thus be rotated.

- If it has not been assembled ex-works, precisely fit the inner knob (5) on the coupling shaft (2) as far as it will go. The inner knob can only be fitted in one position.

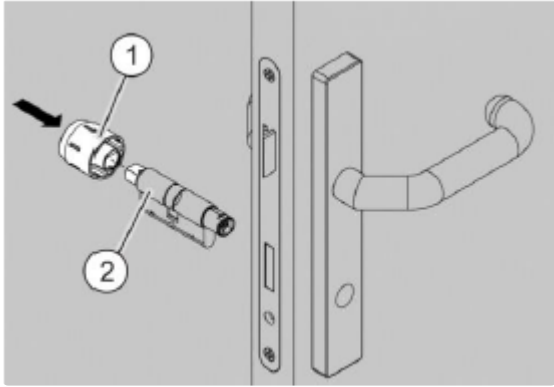

Fig. 17: Fitting the inner knob

- If necessary, turn the inner knob (1) with the coupling shaft so that the set screw (3) is easily accessible for the screwdriver.
- Tighten the M3 set screw (3) in a clockwise direction with a TORX screwdriver (T6) so that it is hand-tight (approx. 4 turns).

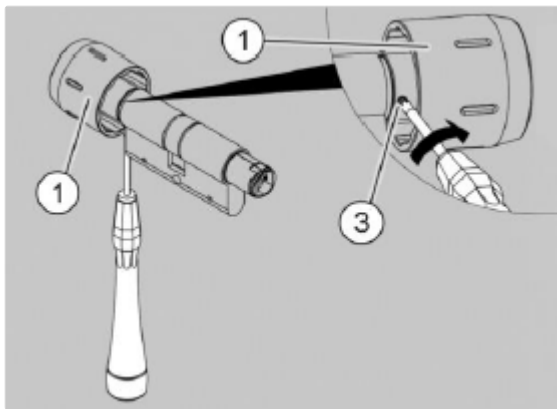

Fig. 18: Tightening the inner knob

- Carefully slide the double cylinder (2) through the handle, door and lock (4) from the inside.

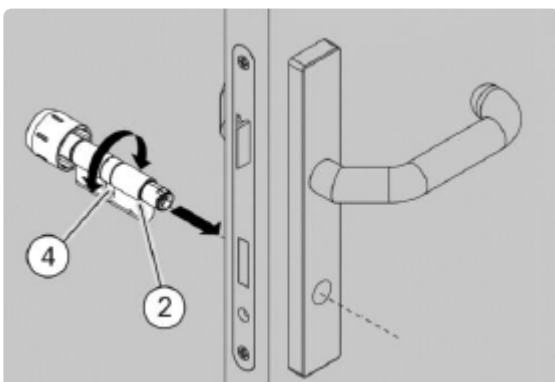

Fig. 19: Inserting the cylinder

! Damage to the cylinder caused by tightening the fixing screw or lock with a cordless screwdriver without torque limitation.

- Tighten the fixing screw with a Phillips screwdriver only so that it is hand-tight.

- Turn the already assembled rotary knob (1) or special key and pull the cylinder forwards and backwards until you have felt the correct locking nose position to drive out the lock's bolt (6).
- Leave the bolt (6) extended until the fixing screw (5) is completely screwed into the cylinder.
- Secure the double cylinder with the fixing screw (5). Do not fully tighten the fixing screw (5) yet.

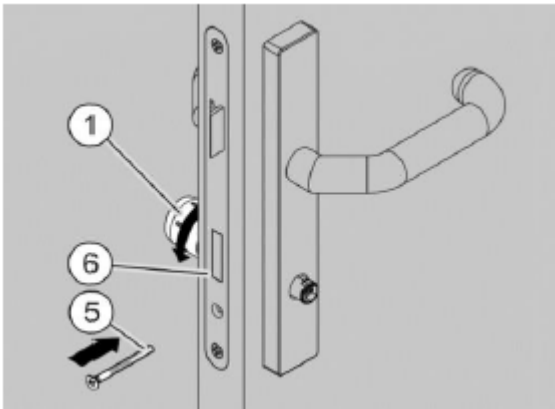

Fig. 20: Aligning the locking nose

! Risk of injury due to short-circuiting when touching the electronics.

- Always hold the electronic knob by the battery pack.

! Electrostatic discharge (sparks or flashover) can destroy electronic components.

- Therefore, before dismantling / assembling the knob sleeve, prevent electrostatic charges or touch a conductive, earthed object (e.g. a water pipe or heater) to electrostatically discharge yourself.
- If necessary, remove the knob sleeve from the electronic knob (8). If necessary, use the knob tool to carefully separate the knob sleeve from the electronic knob.
- Precisely slide the electronic knob (8) onto the coupling shaft as far as it will go. Observe the coupling shaft's and the electronic knob's groove points while doing so. The electronic knob (8) can only be guided onto the coupling shaft in one position.
- Gently push the electronic knob (8) onto the coupling shaft and secure the electronic knob (8) with the fixing bracket (7).

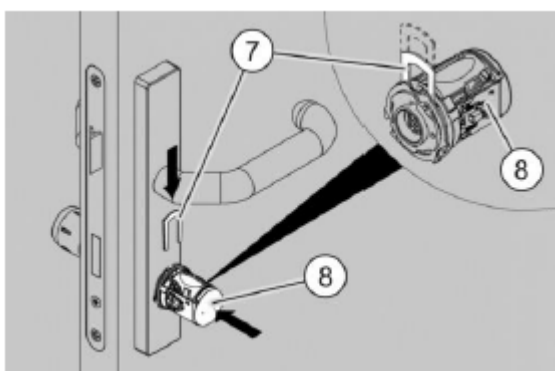

Fig. 21: Assembling the electronic knob

! If the batteries are connected before the electronic knob is assembled, the electronics may be damaged.

- First of all, ensure that the battery pack is inserted but not connected.

✿ The battery plug is designed to be torsion-proof by means of a guide nose.

- If necessary, insert the battery pack (not shown).
- Insert the battery plug (9) into the battery socket (10) and push the battery plug until you hear it click into place. Then push the cables into the corresponding groove (not shown) below the plug.

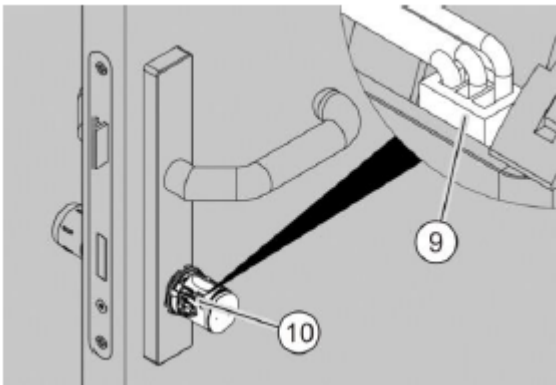

Fig. 22: Connecting the battery

- Attach the knob tool (12) to the bayonet lock. Insert the protruding pins of the knob tool (12) into the recesses of the bayonet disc (13) as shown below so that they can be twisted
- Precisely slide the knob sleeve (11) over the electronic knob. The knob sleeve (11) can only be slid on in one position because the two driving cams on the electronic knob have different widths.

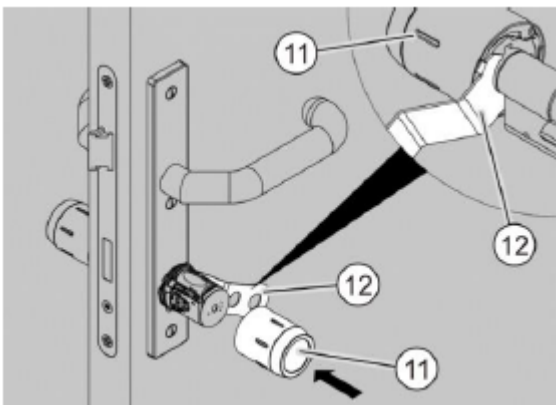

Fig. 23: Sliding on the knob sleeve

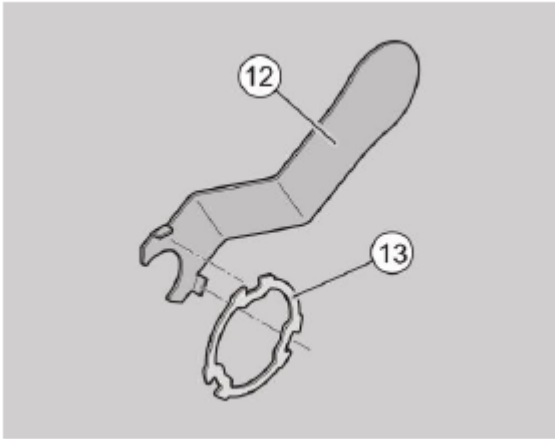

Fig. 24: Attaching the knob tool

- To lock the bayonet lock, turn the knob tool (12) clockwise.
- Ensure that the inner knob and electronic knob can be turned freely without rubbing against the handle.
- Tighten the fixing screw (5) with a Phillips screwdriver so that it is tight.

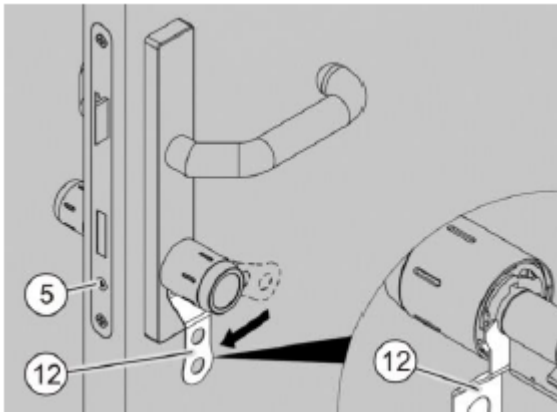

Fig. 25: Locking the bayonet lock

5.4. Assembling the double cylinder that has no inner knob and reads on one side

- * Always assemble the cylinder with the door open so that you do not lock yourself out. The electronic knobs are engaged before initialisation when they are delivered and the cylinder's locking nose can thus be rotated.

- * The following figures are schematic diagrams.

Proceed as follows to assemble the cylinder:

- Measure the door's thickness with the handle.
- Ensure that the double cylinder's basic length is adapted to the measured thickness.

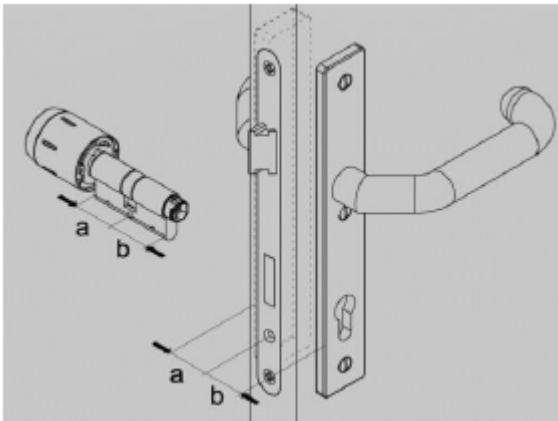

Fig. 26: Measuring the thickness

p(banner important). If the cylinder protrudes more than 3 mm from the handles and rosettes, burglary protection can no longer be guaranteed.

- Always ensure that the cylinder protrudes max. 3 mm from the handles and rosettes.

- ! **Damage to the cylinder caused by tightening the fixing screw or lock with a cordless screwdriver without torque limitation.**

- Tighten the fixing screw with a Phillips screwdriver only so that it is hand-tight.
- Position the locking nose (5) so that it is flush with the cylinder body (4).
- Carefully slide the double cylinder (1) through the handle, door and lock.
- Turn the already assembled rotary knob or special key and pull the cylinder forwards and backwards until you have felt the correct locking nose position to drive out the lock's bolt (3).
- Leave the bolt (3) extended.
- Ensure that the electronic knob can be turned freely without rubbing against the handle.

- Tighten the fixing screw (2) with a Phillips screwdriver so that it is tight.

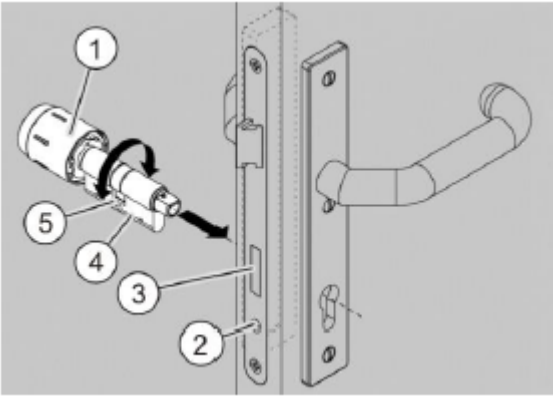

Fig. 27: Inserting the cylinder

5.5. Assembling the double cylinder that has no inner knob but does have a core pulling protection extension (CPPE)

* The following describes the assembly process for protective handles or for rosettes with round holes, for which the core cover usually has to be removed before assembly. Due to the large number of handles and rosettes available on the market, the individual handles and rosettes are not shown here, and dismantling of the core cover is not described.

* The following figures are schematic diagrams.

Proceed as follows to assemble the cylinder

- Measure the door's thickness with the handle.
- Ensure that the cylinder's basic length is adapted to the measured thickness. Note the division into outside (a) and inside (b) in this regard.

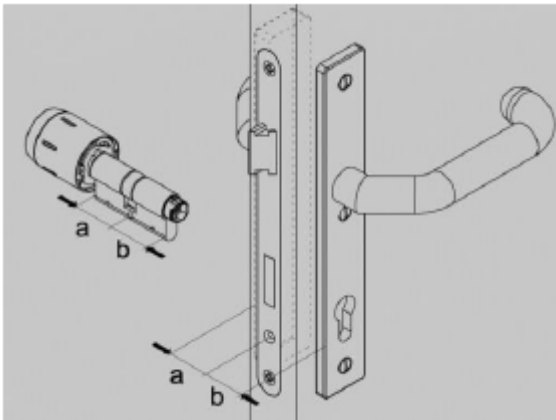

Fig. 28: Measuring the thickness

* The cylinder with the core pulling protection extension must be inserted into the installation hole from the inside to the outside. The side with the core pulling protection extension should be on the outside.

- Position the locking nose (1) so that it is flush with the cylinder body.
- Carefully slide the cylinder through the handle, door and lock (2) from the inside.

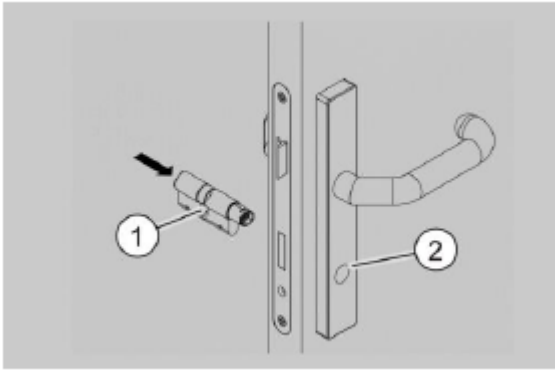

Fig. 29: Inserting the cylinder

! Damage to the cylinder caused by tightening the fixing screw or lock with a cordless screwdriver without torque limitation.

- Tighten the fixing screw with a Phillips screwdriver only so that it is hand-tight.
- Secure the double cylinder (3) with the fixing screw (4). Do not fully tighten the fixing screw (4) yet.

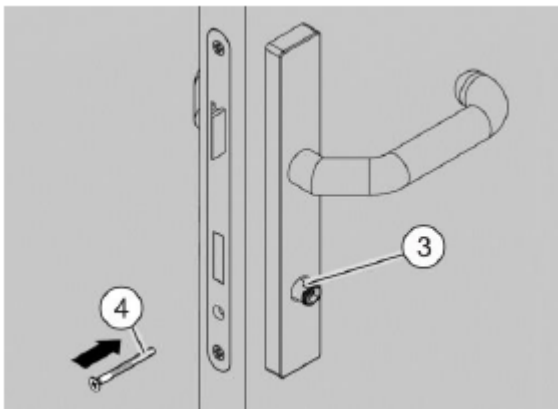

Fig. 30: Securing the cylinder

! Risk of injury due to short-circuiting when touching the electronics.

- Always hold the electronic knob by the battery pack.

! Electrostatic discharge (sparks or flashover) can destroy electronic components.

- Therefore, before dismantling / assembling the knob sleeve, prevent electrostatic charges or touch a conductive, earthed object (e.g. a water pipe or heater) to electrostatically discharge yourself.
- If necessary, remove the knob sleeve from the electronic knob (6). If necessary, use the knob tool to carefully separate the knob sleeve from the electronic knob (6).
- Precisely slide the electronic knob (6) onto the coupling shaft as far as it will go. Observe the coupling shaft's and the electronic knob's (6) groove points while doing so. The electronic knob (6)

can only be guided onto the coupling shaft in one position.

- Gently push the electronic knob (6) onto the coupling shaft and secure the electronic knob (6) with the fixing bracket (5).

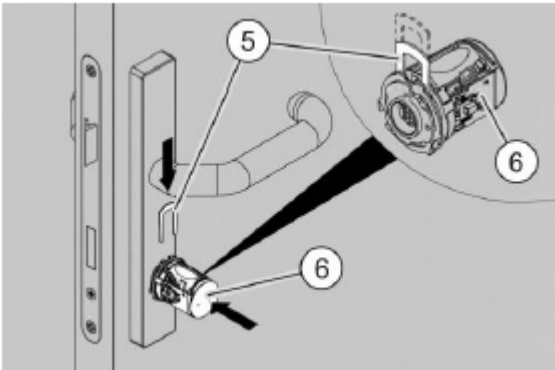

Fig. 31: Assembling the electronic knob

! If the batteries are connected before the electronic knob is assembled, the electronics may be damaged.

- First of all, ensure that the battery pack is inserted but not connected.

***** The battery plug is designed to be torsion-proof by means of a guide nose.

- If necessary, insert the battery pack into the battery socket (not shown).
- Insert the battery plug (7) into the battery socket (8) and push the battery plug until you hear it click into place. Then push the cables into the corresponding groove (not shown) below the plug.

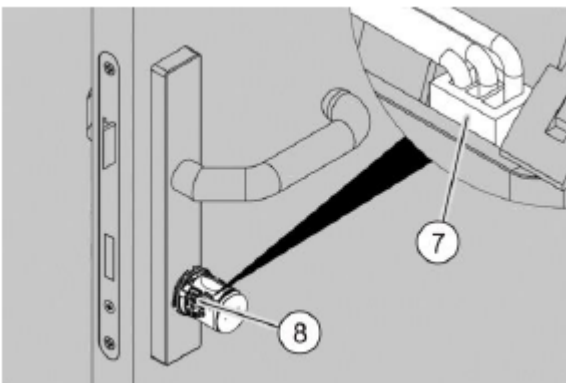

Fig. 32: Connecting the battery

- Attach the knob tool (10) to the bayonet lock. Insert the protruding pins of the knob tool into the recesses of the bayonet disc (11) as shown below so that they can be twisted.
- Precisely slide the knob sleeve (9) over the electronic knob. The knob sleeve (9) can only be slid on in one position because the two driving cams on the electronic knob have different widths.

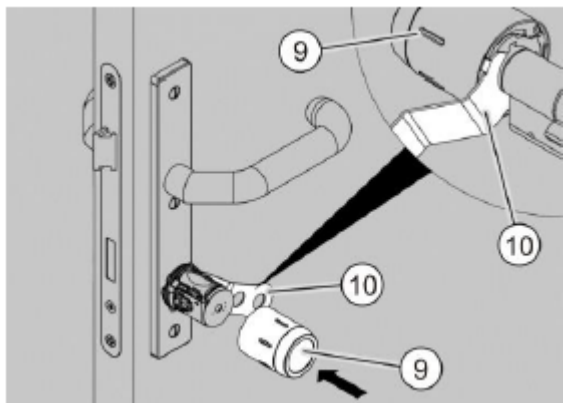

Fig. 33: Attaching the knob sleeve

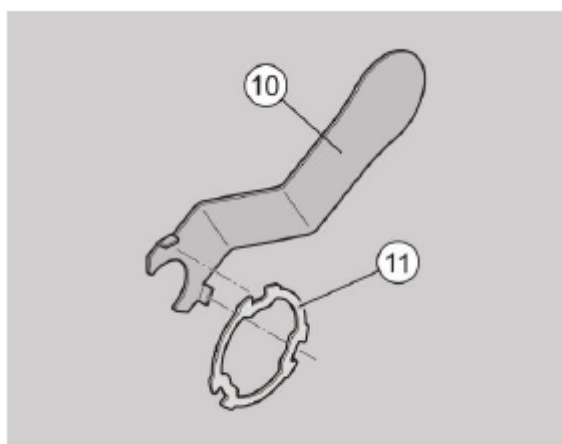

Fig. 34: Attaching the knob tool

- To lock the bayonet lock, turn the knob tool (10) clockwise.
- Ensure that the electronic knob can be turned freely without rubbing against the handle.
- Tighten the fixing screw (4) with a Phillips screwdriver so that it is hand-tight.

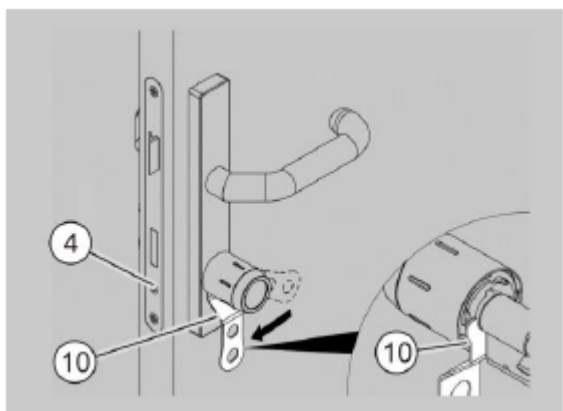

Fig. 35: Locking the bayonet lock

5.6. Assembling the double cylinder that reads on both sides

* The double cylinder that reads on both sides has the same electronic and mechanical security mechanisms on both sides (including drilling protection on both sides). There is no difference between the inside and outside. If there is a difference in length between the outside and the inside, consider the installation direction according to your installation situation.

* Always assemble the cylinder with the door open so that you do not lock yourself out. The electronic knobs are engaged before initialisation when they are delivered and the cylinder's locking nose can thus be rotated.

* The following figures are schematic diagrams.

Proceed as follows to assemble the double cylinder:

- Measure the door's thickness with the handle.
- Ensure that the cylinder's basic length is adapted to the measured thickness. Note the division into outside (a) and inside (b) in this regard.

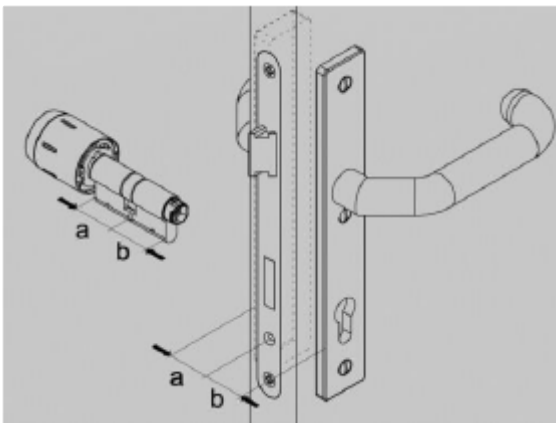

Fig. 36: Measuring the thickness

! If the cylinder protrudes more than 3 mm from the handles and rosettes, burglary protection can no longer be guaranteed.

- Always ensure that the cylinder protrudes max. 3 mm from the handles and rosettes.
- Position the locking nose (3) so that it is flush with the cylinder body (2).
- Carefully slide the double cylinder (1) through the handle, door and lock in the direction of the arrow.

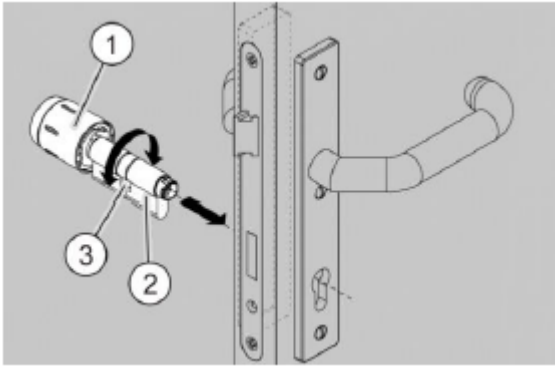

Fig. 37: Aligning the locking nose

! Damage to the cylinder caused by tightening the fixing screw or lock with a cordless screwdriver without torque limitation.

- Tighten the fixing screw with a Phillips screwdriver only so that it is hand-tight.
- Turn the already assembled rotary knob (1) or special key and pull the cylinder forwards and backwards until you have felt the correct locking nose position to drive out the bolt (5).
- Leave the bolt (5) extended until the fixing screw (4) is completely screwed into the cylinder.
- Secure the cylinder (1) with the fixing screw (4). Do not tighten the fixing screw (4) with a Phillips screwdriver so that it is tight yet.

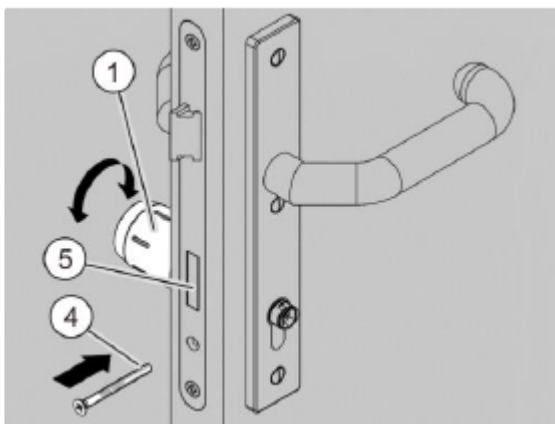

Fig. 38: Inserting the cylinder

! Risk of injury due to short-circuiting when touching the electronics.

- Always hold the electronic knob by the battery pack.

! Electrostatic discharge (sparks or flashover) can destroy electronic components.

- Therefore, before dismantling / assembling the knob sleeve, prevent electrostatic charges or touch a conductive, earthed object (e.g. a water pipe or heater) to electrostatically discharge yourself.

- If necessary, remove the knob sleeve from the electronic knob (7). If necessary, use the knob tool to carefully separate the sleeve from the electronic knob.
- Precisely slide the electronic knob (7) onto the coupling shaft as far as it will go. Observe the coupling shaft's and the electronic knob's groove points while doing so. The electronic knob (7) can only be guided onto the shaft in one position.
- Gently push the electronic knob (7) onto the coupling shaft and secure the electronic knob (7) with the fixing bracket (6).

!{IMAGE-LFig. INK+elektronikknauf-montieren3}!

Fig. 39: Assembling the electronic knob

! If the batteries are connected before the electronic knob is assembled, the electronics may be damaged.

- First of all, ensure that the battery pack is inserted but not connected.

***** The battery plug is designed to be torsion-proof by means of a guide nose.

- If necessary, insert the battery pack (not shown).
- Insert the battery plug (8) into the battery socket (9) and push the battery plug until you hear it click into place. Then push the cables into the corresponding groove (not shown) below the plug.

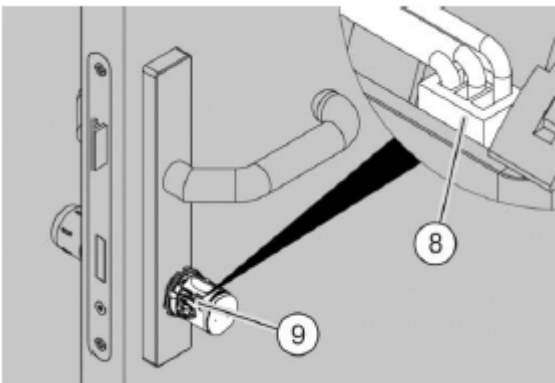

Fig. 40: Connecting the battery

- Attach the knob tool (11) to the bayonet lock. Insert the protruding pins of the knob tool (11) into the recesses of the bayonet disc (12) as shown below so that they can be twisted
- Precisely slide the knob sleeve (10) over the electronic knob. The knob sleeve (10) can only be slid on in one position because the two driving cams on the electronic knob have different widths.

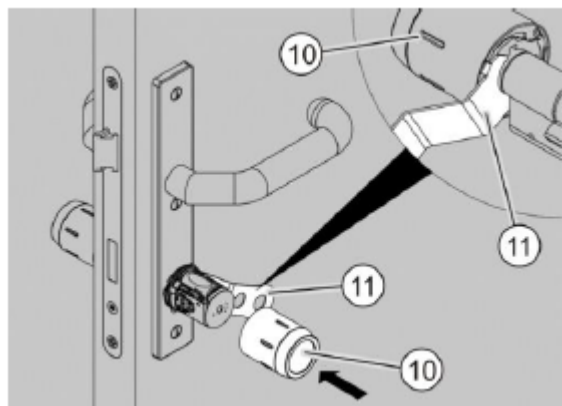

Fig. 41: Sliding on the knob sleeve

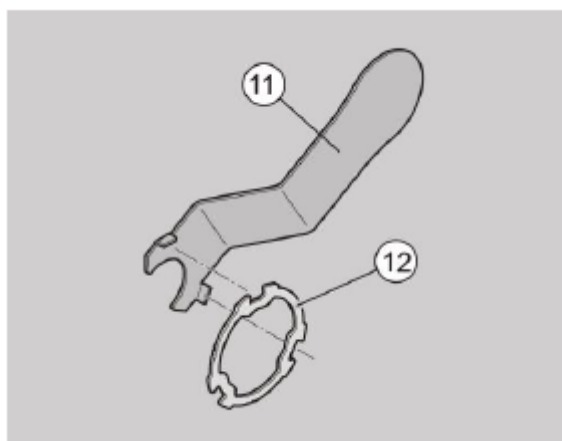

Fig. 42: Attaching the knob tool

- To lock the bayonet lock, turn the knob tool (11) clockwise.
- Ensure that the two electronic knobs can be turned freely without rubbing against the handle.
- Tighten the fixing screw (4) with a Phillips screwdriver so that it is hand-tight.

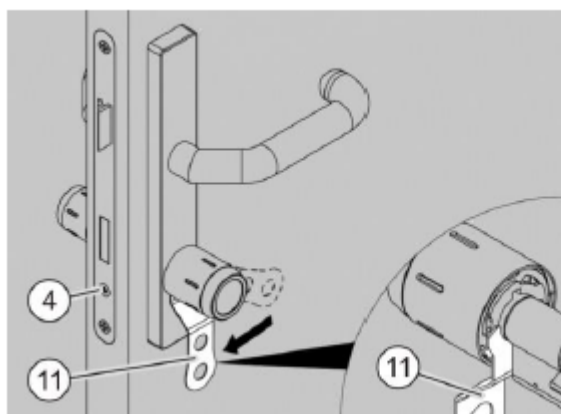

Fig. 43: Locking the bayonet lock

5.7. Assembling the double cylinder that has a core pulling protection extension (CPPE) and reads on both sides

* The double cylinder that reads on both sides has the same electronic and mechanical security mechanisms on both sides (including drilling protection on both sides). There is no difference between the inside and outside. If there is a difference in length between the outside and the inside, consider the installation direction according to your installation situation.

* The following describes the assembly process for protective handles or for rosettes with round holes, for which the core cover usually has to be removed before assembly. Due to the large number of handles and rosettes available on the market, the individual handles and rosettes are not shown here, and dismantling of the core cover is not described.

* Always assemble the cylinder with the door open so that you do not lock yourself out. The electronic knobs are engaged before initialisation when they are delivered and the cylinder's locking nose can thus be rotated.

* The following figures are schematic diagrams.

Proceed as follows to assemble the double cylinder:

- Measure the door's thickness with the handle.
- Ensure that the cylinder's basic length is adapted to the measured thickness. Note the division into outside (a) and inside (b) in this regard.

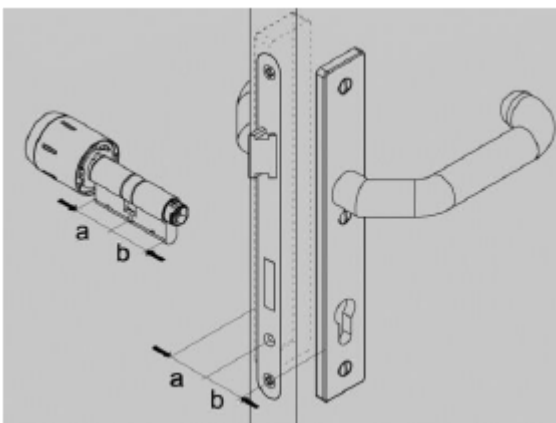

Fig. 44: Measuring the thickness

- Position the locking nose (3) so that it is flush with the cylinder body (2).

- Carefully slide the double cylinder (1) through the handle, door and lock in the direction of the arrow.

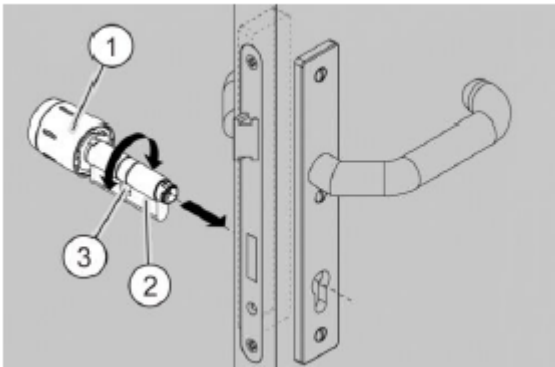

Fig. 45: Aligning the locking nose

! **Damage to the cylinder caused by tightening the fixing screw or lock with a cordless screwdriver without torque limitation.**

- Tighten the fixing screw with a Phillips screwdriver only so that it is hand-tight.
- Turn the already assembled rotary knob (1) or special key and pull the cylinder forwards and backwards until you have felt the correct locking nose position to drive out the bolt (5).
- Leave the bolt (5) extended until the fixing screw (4) is completely screwed into the cylinder.
- Secure the cylinder (1) with the fixing screw (4). Do not tighten the fixing screw (4) with a Phillips screwdriver so that it is tight yet.

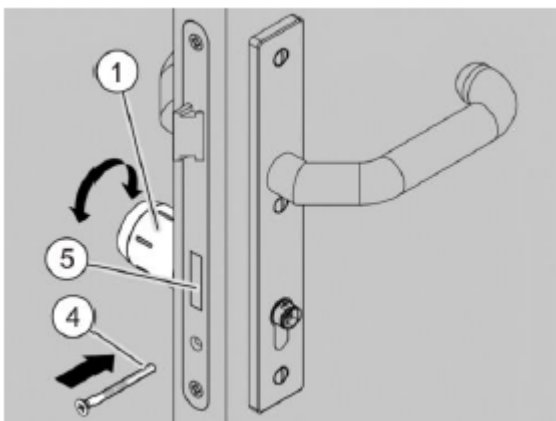

Fig. 46: Inserting the cylinder

! **Risk of injury due to short-circuiting when touching the electronics.**

- Always hold the electronic knob by the battery pack.

! **Electrostatic discharge (sparks or flashover) can destroy electronic components.**

- Therefore, before dismantling / assembling the knob sleeve, prevent electrostatic charges or touch a conductive, earthed object (e.g. a water pipe or heater) to electrostatically discharge yourself.
- If necessary, remove the knob sleeve from the electronic knob (7). If necessary, use the knob tool to carefully separate the sleeve from the electronic knob.
- Precisely slide the electronic knob (7) onto the coupling shaft as far as it will go. Observe the coupling shaft's and the electronic knob's groove points while doing so. The electronic knob can only be guided onto the coupling shaft in one position.
- Gently push the electronic knob (7) onto the coupling shaft and secure the electronic knob (7) with the fixing bracket (6).

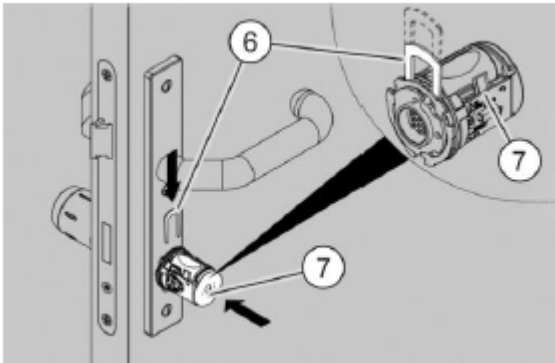

Fig. 47: Assembling the electronic knob

! If the batteries are connected before the electronic knob is assembled, the electronics may be damaged.

- First of all, ensure that the battery pack is inserted but not connected.

***** The battery plug is designed to be torsion-proof by means of a guide nose.

- If necessary, insert the battery pack (not shown).
- Insert the battery plug (8) into the battery socket (9) and push the battery plug until you hear it click into place. Then push the cables into the corresponding groove (not shown) below the plug.

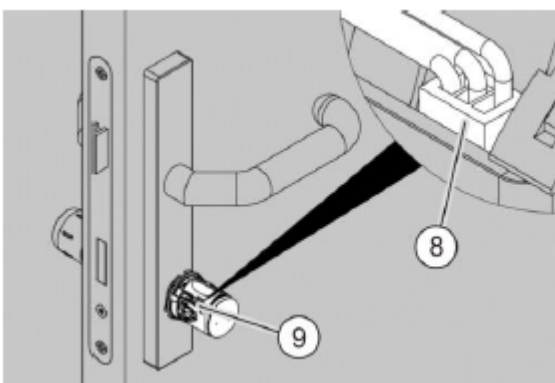

Fig. 48: Connecting the battery

- Attach the knob tool (11) to the bayonet lock. Insert the protruding pins of the knob tool (11) into the recesses of the bayonet disc (12) as shown below so that they can be twisted
- Precisely slide the knob sleeve (10) over the electronic knob. The knob sleeve (10) can only be slid on in one position because the two driving cams on the electronic knob have different widths.

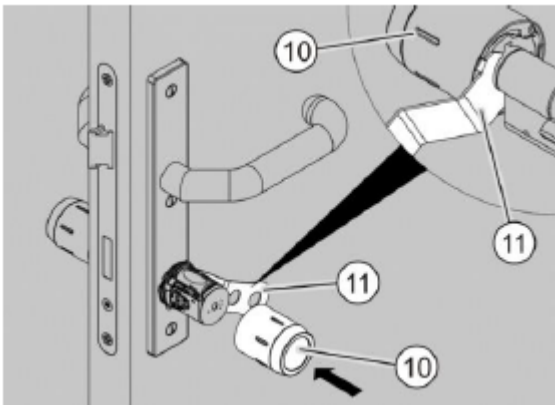

Fig. 49: Sliding on the knob sleeve

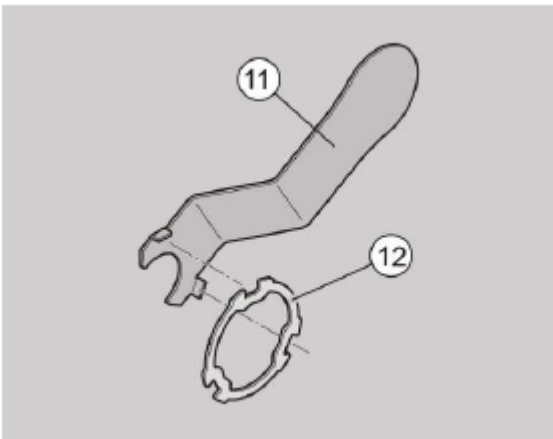

Fig. 50: Attaching the knob tool

- To lock the bayonet lock, turn the knob tool (11) clockwise.
- Ensure that the two electronic knobs can be turned freely without rubbing against the handle.
- Tighten the fixing screw (4) with a Phillips screwdriver so that it is hand-tight.

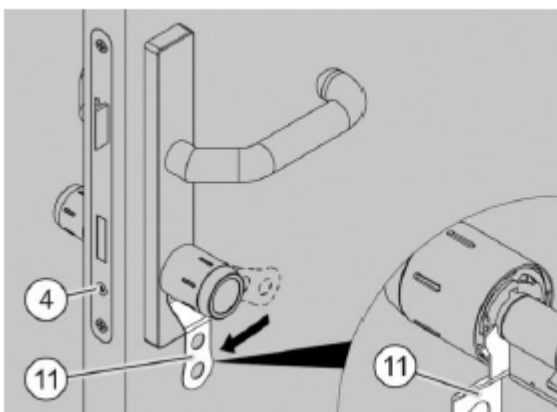

Fig. 51: Locking the bayonet lock

5.8. Assembling the short / long (SL) cylinder that reads on one side

* The cylinder that reads on one side is usually assembled from the outside. If assembly from the inside is necessary, proceed in reverse order to assemble an electronic knob, as described in the section entitled Double cylinder that reads on both sides from page 45 onwards.

* Always assemble the cylinder with the door open so that you do not lock yourself out. The electronic knobs are engaged before initialisation when they are delivered and the cylinder's locking nose can thus be rotated.

* The following figures are schematic diagrams.

Proceed as follows to assemble the short / long cylinder:

- Measure the door's thickness with the handle.
- Ensure that the cylinder's basic length is adapted to the measured thickness. Note the division into outside (a) and inside (b) in this regard.

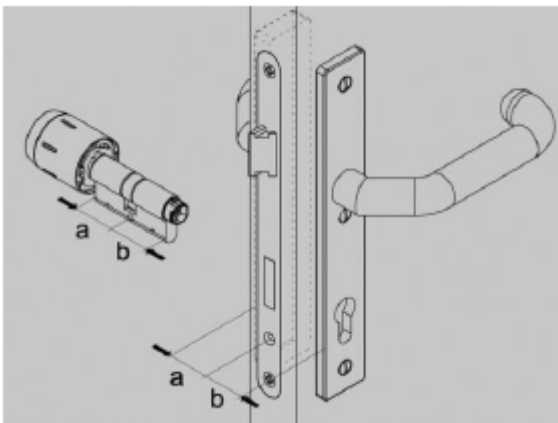

Fig. 52: Measuring the thickness

! If the cylinder protrudes more than 3 mm from the handles and rosettes, burglary protection can no longer be guaranteed.

- Always ensure that the cylinder protrudes max. 3 mm from the handles and rosettes.
- Position the locking nose (3) so that it is flush with the cylinder body (2).
- Carefully slide the cylinder (1) through the handle, door and lock from the outside.

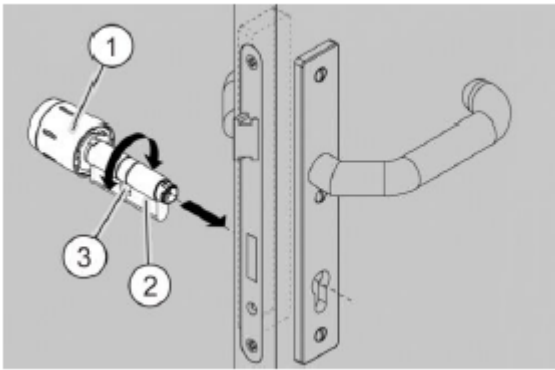

Fig. 53: Inserting the cylinder

! Damage to the cylinder caused by tightening the fixing screw or lock with a cordless screwdriver without torque limitation.

- Tighten the fixing screw with a Phillips screwdriver only so that it is hand-tight.
- Turn the already assembled rotary knob or special key and pull the cylinder (1) forwards and backwards until you have felt the correct locking nose position to drive out the lock's bolt (5).
- Leave the bolt (5) extended until the fixing screw (4) is completely screwed into the cylinder.
- Secure the short / long cylinder with the fixing screw (4). Do not fully tighten the fixing screw (4) yet.

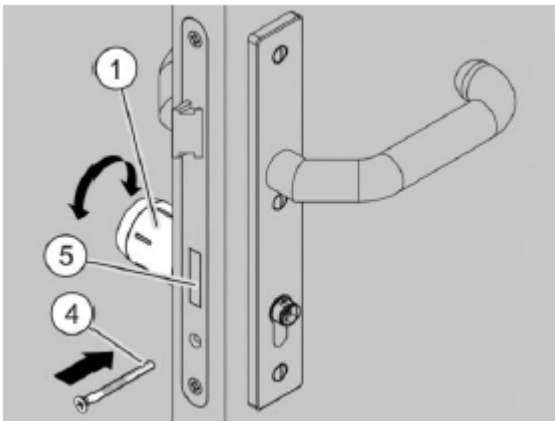

Fig. 54: Aligning the locking nose

- Precisely fit the inner knob (6) onto the cylinder's (1) coupling shaft as far as it will go. The inner knob (6) can only be fitted in one position.

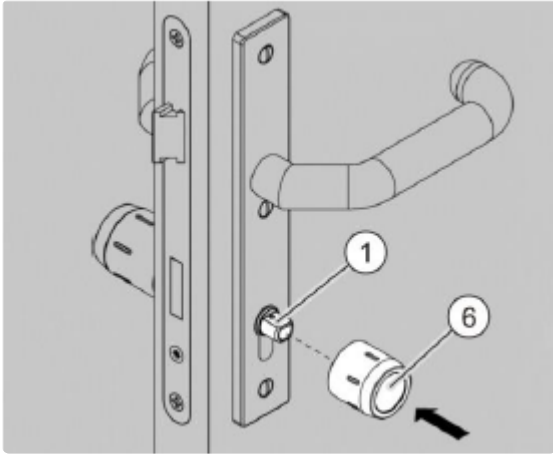

Fig. 55: Fitting the inner knob

- If necessary, turn the inner knob (5) with the coupling shaft so that the set screw (6) is easily accessible for the screwdriver.
- Tighten the M3 set screw (6) in a clockwise direction with a TORX screwdriver (T6) so that it is hand-tight (approx. 4 turns).
- Ensure that the inner knob and electronic knob can be turned freely without rubbing against the handle.
- Tighten the fixing screw (4) with a Phillips screwdriver so that it is hand-tight.

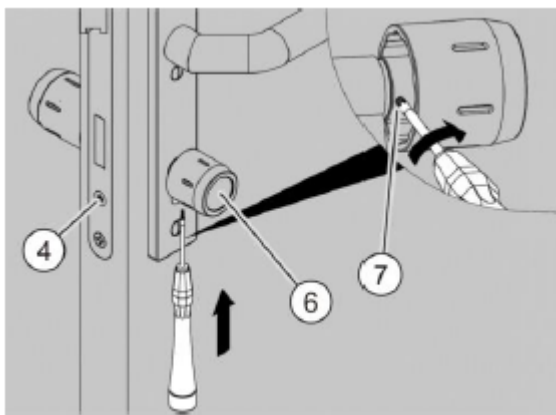

Fig. 56: Securing the inner knob

5.9. Assembling the short / long cylinder that has a core pulling protection extension (CPPE) and reads on one side

* The following describes the assembly process for protective handles or for rosettes with round holes, for which the core cover usually has to be removed before assembly. Due to the large number of handles and rosettes available on the market, the individual handles and rosettes are not shown here, and dismantling of the core cover is not described.

* The cylinder with the core pulling protection extension must be inserted into the installation hole from the inside to the outside. The side with the core pulling protection extension should be on the outside.

* The following figures are schematic diagrams.

Proceed as follows to assemble the short / long cylinder:

- Measure the door's thickness with the handle.
- Ensure that the cylinder's basic length is adapted to the measured thickness. Note the division into outside (a) and inside (b) in this regard.

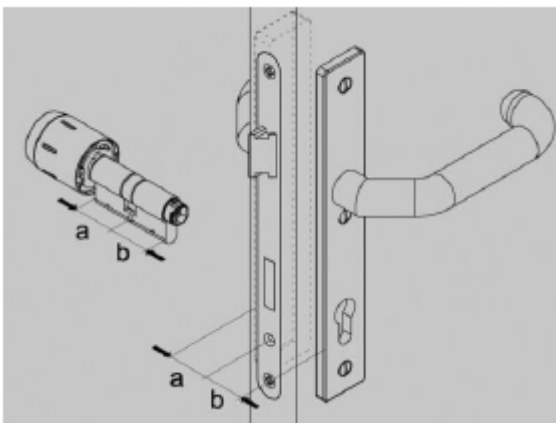

Fig. 57: Measuring the thickness

* Always assemble the cylinder with the door open so that you do not lock yourself out. The electronic knobs are engaged before initialisation when they are delivered and the cylinder's locking nose can thus be rotated.

- If it has not been assembled on the coupling shaft (2) ex-works, precisely fit the inner knob (1) as far as it will go. The inner knob can only be fitted in one position.

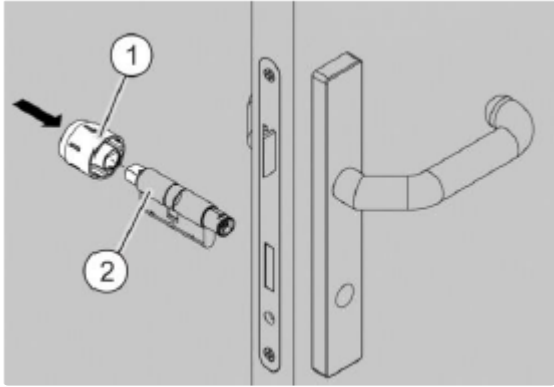

Fig. 58: Fitting the inner knob

- If necessary, turn the inner knob (1) with the coupling shaft so that the set screw (3) is easily accessible for the screwdriver.
- Tighten the M3 set screw (3) in a clockwise direction with a TORX screwdriver (T6) so that it is hand-tight (approx. 4 turns).

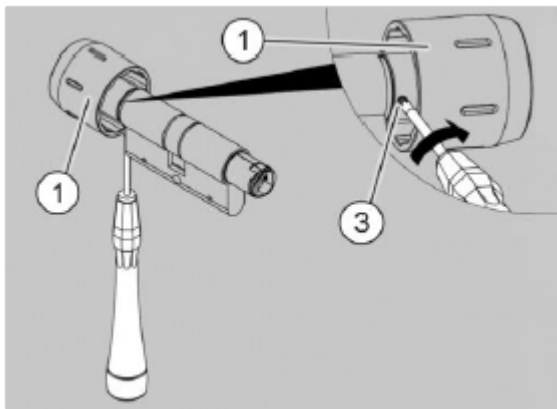

Fig. 59: Tightening the inner knob

- Position the locking nose (4) so that it is flush with the cylinder.
- Carefully slide the short / long cylinder (2) through the handle, door and lock from the inside.

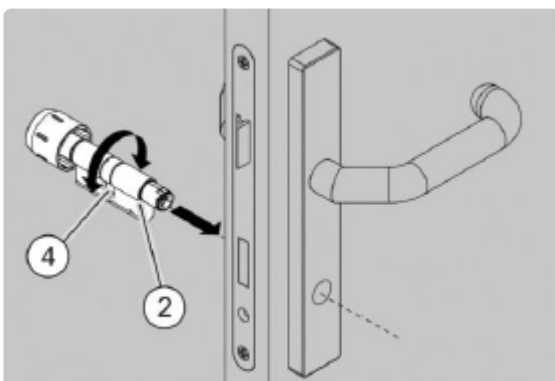

Fig. 60: Inserting the cylinder

! Damage to the cylinder caused by tightening the fixing screw or lock with a cordless screwdriver without torque limitation.

- Tighten the fixing screw with a Phillips screwdriver only so that it is hand-tight.

- Turn the already assembled rotary knob (1) or special key and pull the cylinder forwards and backwards until you have felt the correct locking nose position to extend the bolt (6).
- Leave the bolt (6) extended until the fixing screw (5) is completely screwed into the cylinder.
- Secure the short / long cylinder with the fixing screw (5). Do not fully tighten the fixing screw (5) yet.

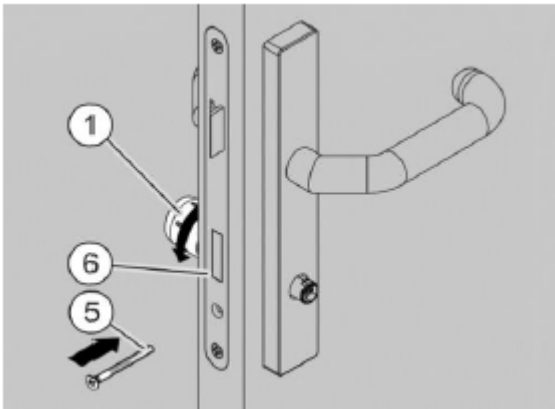

Fig. 61: Aligning the locking nose

! Risk of injury due to short-circuiting when touching the electronics.

- Always hold the electronic knob by the battery pack.

! Electrostatic discharge (sparks or flashover) can destroy electronic components.

- Therefore, before dismantling / assembling the knob sleeve, prevent electrostatic charges or touch a conductive, earthed object (e.g. a water pipe or heater) to electrostatically discharge yourself.
- If necessary, remove the knob sleeve from the electronic knob (8). If necessary, use the knob tool to carefully separate the knob sleeve from the electronic knob.
- Precisely slide the electronic knob (8) onto the coupling shaft as far as it will go. Observe the coupling shaft's and the electronic knob's groove points while doing so. The electronic knob (8) can only be guided onto the coupling shaft in one position.
- Gently push the electronic knob (8) onto the coupling shaft and secure the electronic knob (8) with the fixing bracket (7).

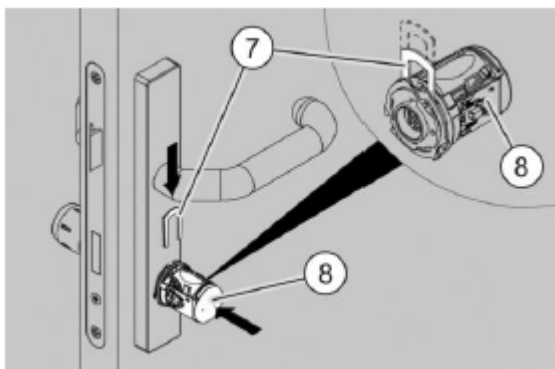

Fig. 62: Assembling the electronic knob

! If the batteries are connected before the electronic knob is assembled, the electronics may be damaged.

- First of all, ensure that the battery pack is inserted but not connected.

***** The battery plug is designed to be torsion-proof by means of a guide nose.

- If necessary, insert the battery pack (not shown).
- Insert the battery plug (9) into the battery socket (10) and push the battery plug until you hear it click into place. Then push the cables into the corresponding groove (not shown) below the plug.

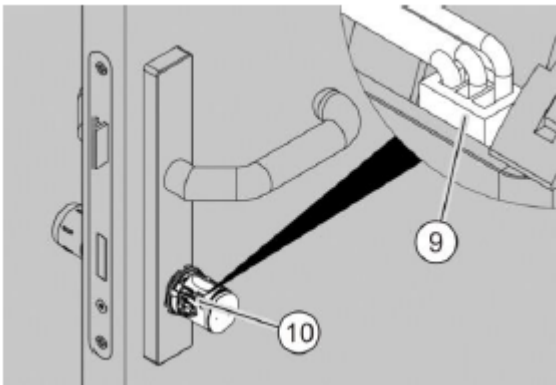

Fig. 63: Connecting the battery

- Attach the knob tool (12) to the bayonet lock. Insert the protruding pins of the knob tool (12) into the recesses of the bayonet disc (13) as shown below so that they can be twisted
- Precisely slide the knob sleeve (11) over the electronic knob. The knob sleeve (11) can only be slid on in one position because the two driving cams on the electronic knob have different widths.

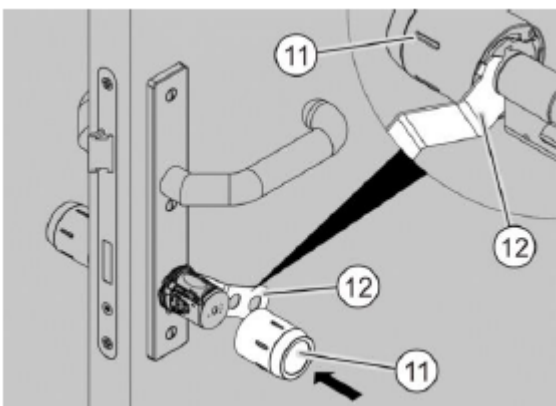

Fig. 64: Sliding on the knob sleeve

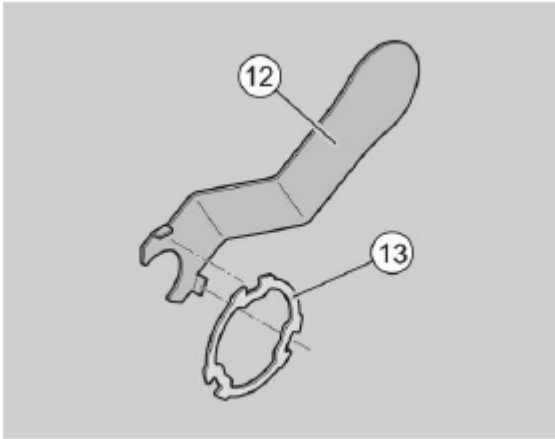

Fig. 65: Attaching the knob tool

- To lock the bayonet lock, turn the knob tool (12) clockwise.
- Ensure that the knobs can be turned freely without rubbing against the handle or rosettes.
- Tighten the fixing screw (5) with a Phillips screwdriver so that it is hand-tight.

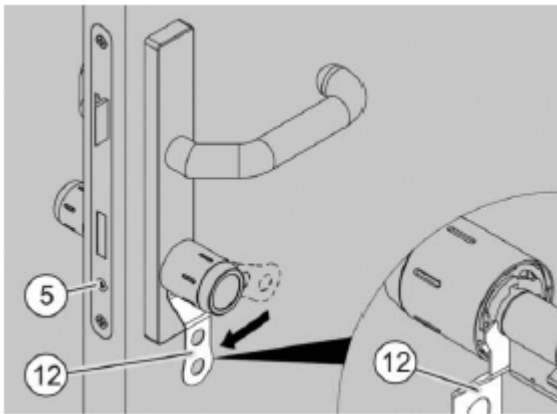

Fig. 66: Locking the bayonet lock

5.10. 456

5.11. 123

5.12. Assembling the glass door cylinder that reads on one side

(banner tip). The glass door cylinder that reads on one side is usually assembled from the outside. If assembly from the inside is necessary, dismantle the knob sleeve and the electronics in reverse order; proceed as follows in this regard as described in the section entitled Double cylinder that reads on both sides from page 45 onwards.

- * Always assemble the cylinder with the door open so that you do not lock yourself out. The electronic knobs are engaged before initialisation when they are delivered and the cylinder's locking nose can thus be rotated.

- * In the case of glass doors, the lock is a combination of a lock and an internal handle behind the pane of glass. The figures below show how to assemble a cylinder on a wooden or plastic door. The cylinder is assembled in the exact same way regardless of the door material.

Proceed as follows to assemble the glass door cylinder:

- Measure the door's thickness with the handle.
- Ensure that the cylinder's basic length is adapted to the measured thickness. Note the division into outside (a) and inside (b) in this regard.

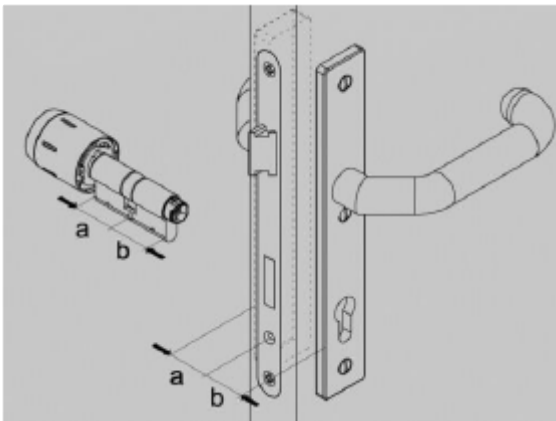

Fig. 67: Measuring the thickness

- * If the cylinder protrudes more than 3 mm from the handles and rosettes, burglary protection can no longer be guaranteed.

- Always ensure that the cylinder protrudes max. 3 mm from the handles and rosettes.
- Position the locking nose (3) so that it is flush with the cylinder body (2).
- Carefully slide the glass door cylinder (1) through the handle, door or lock from the outside in the

direction of the arrow.

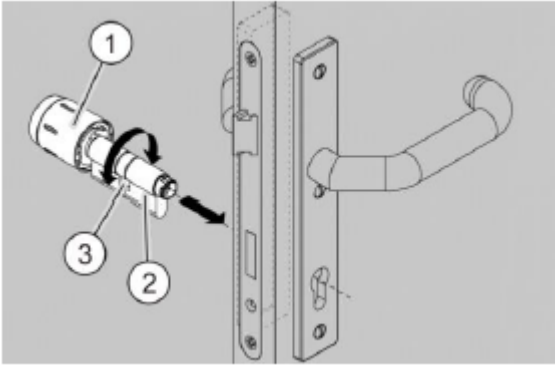

Fig. 68: Inserting the cylinder

! Damage to the cylinder caused by tightening the fixing screw or lock with a cordless screwdriver without torque limitation.

- Tighten the fixing screw with a Phillips screwdriver only so that it is hand-tight.
- Turn the already assembled rotary knob (1) or special key and pull the cylinder forwards and backwards until you have felt the correct locking nose position to drive out the lock's bolt (5).
- Leave the bolt (5) driven out until the fixing screw (4) is completely screwed into the cylinder.
- Secure the glass door cylinder with the fixing screw (4). Do not fully tighten the fixing screw (4) yet.

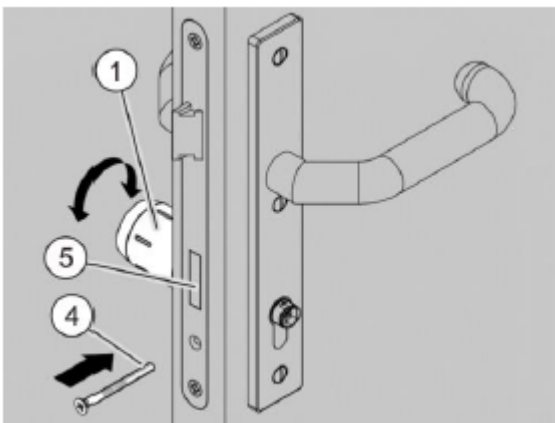

Fig. 69: Aligning the locking nose

- Precisely fit the inner knob (6) onto the cylinder's (1) coupling shaft as far as it will go. The inner knob (6) can only be fitted in one position.

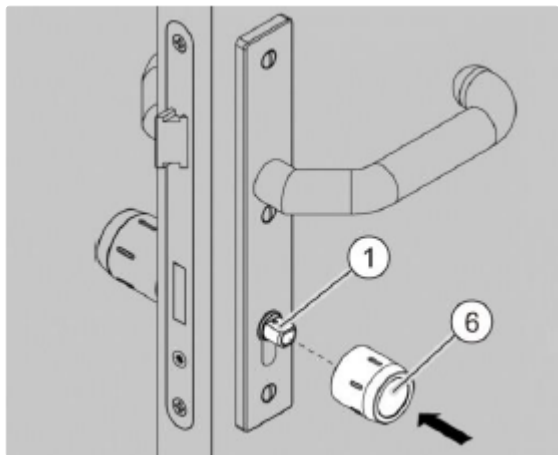

Fig. 70: Fitting the inner knob

- If necessary, turn the inner knob (6) with the coupling shaft so that the set screw (7) is easily accessible for the screwdriver.
- Tighten the M3 set screw (7) in a clockwise direction with a TORX screwdriver (T6) so that it is hand-tight (approx. 4 turns).
- Ensure that the inner knob and electronic knob can be turned freely without rubbing against the handle.
- Tighten the fixing screw (4) with a Phillips screwdriver so that it is hand-tight.

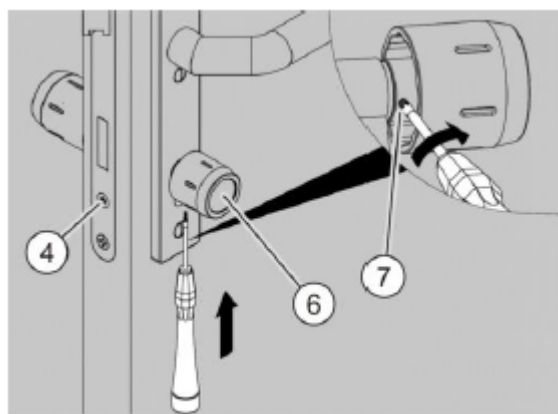

Fig. 71: Securing the inner knob

5.13. Assembling the glass door cylinder that has a core pulling protection extension (CPPE) and reads on one side

* The following describes the assembly process for protective handles or for rosettes with round holes, for which the core cover usually has to be removed before assembly. Due to the large number of handles and rosettes available on the market, the individual handles and rosettes are not shown here, and dismantling of the core cover is not described.

* In the case of glass doors, the lock is a combination of a lock and an internal handle behind the pane of glass. The figures below show how to assemble a cylinder on a wooden or plastic door. The cylinder is assembled in the exact same way regardless of the door material.

Proceed as follows to assemble the glass door cylinder:

- Measure the door's thickness with the handle.
- Ensure that the cylinder's basic length is adapted to the measured thickness. Note the division into outside (a) and inside (b) in this regard.

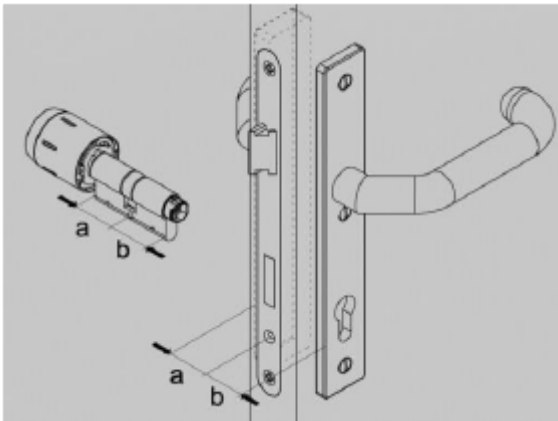

Fig. 72: Measuring the thickness

* The cylinder with the core pulling protection extension must be inserted into the installation hole from the inside to the outside. The side with the core pulling protection extension should be on the outside.

* Always assemble the cylinder with the door open so that you do not lock yourself out. The electronic knobs are engaged before initialisation when they are delivered and the cylinder's locking nose can thus be rotated.

- If it has not been assembled ex-works, precisely fit the inner knob (5) on the coupling shaft (2) as far as it will go. The inner knob can only be fitted in one position.

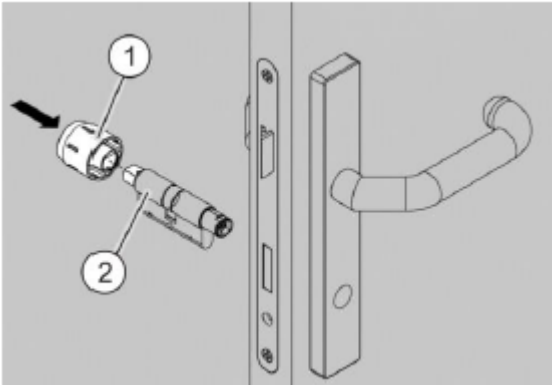

Fig. 73: Fitting the inner knob

- If necessary, turn the inner knob (1) with the coupling shaft so that the set screw (3) is easily accessible for the screwdriver.
- Tighten the M3 set screw (3) in a clockwise direction with a TORX screwdriver (T6) so that it is hand-tight (approx. 4 turns).

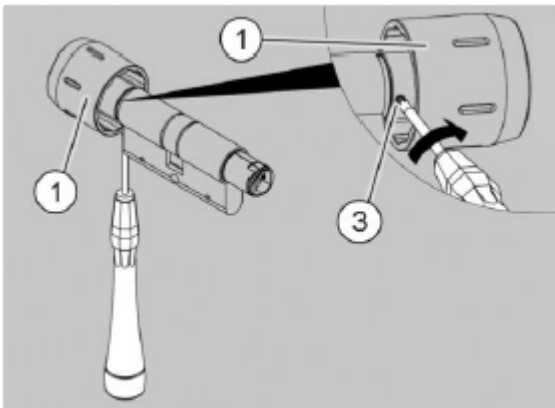

Fig. 74: Tightening the inner knob

- Carefully slide the double cylinder (2) through the handle, door and lock (4) from the inside.

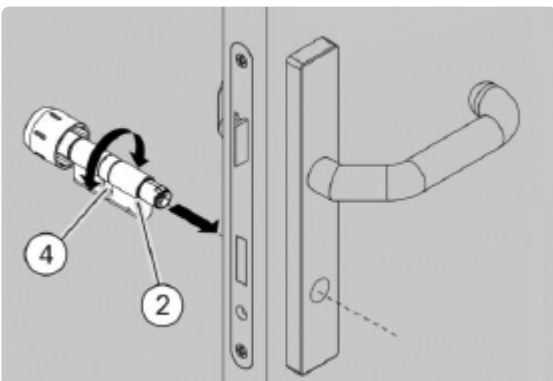

Fig. 75: Inserting the cylinder

! Damage to the cylinder caused by tightening the fixing screw or lock with a cordless screwdriver without torque limitation.

- Tighten the fixing screw with a Phillips screwdriver only so that it is hand-tight.
- Turn the already assembled rotary knob (1) or special key and pull the cylinder forwards and backwards until you have felt the correct locking nose position to drive out the lock's bolt (6).
- Leave the bolt (6) extended until the fixing screw (5) is completely screwed into the cylinder.
- Secure the double cylinder with the fixing screw (5). Do not fully tighten the fixing screw (5) yet.

!{IMFig. AGE-LINK+schliessnase-ausrichten2}!

Fig. 76: Aligning the locking nose

! Risk of injury due to short-circuiting when touching the electronics.

- Always hold the electronic knob by the battery pack.

! Electrostatic discharge (sparks or flashover) can destroy electronic components.

- Therefore, before dismantling / assembling the knob sleeve, prevent electrostatic charges or touch a conductive, earthed object (e.g. a water pipe or heater) to electrostatically discharge yourself.
- If necessary, remove the knob sleeve from the electronic knob (8). If necessary, use the knob tool to carefully separate the knob sleeve from the electronic knob.
- Precisely slide the electronic knob (8) onto the coupling shaft as far as it will go. Observe the coupling shaft's and the electronic knob's groove points while doing so. The electronic knob (8) can only be guided onto the coupling shaft in one position.
- Gently push the electronic knob (8) onto the coupling shaft and secure the electronic knob (8) with the fixing bracket (7).

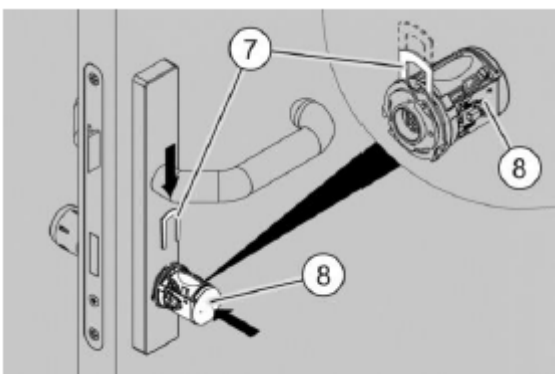

Fig. 77: Assembling the electronic knob

! If the batteries are connected before the electronic knob is assembled, the electronics may be damaged.

- First of all, ensure that the battery pack is inserted but not connected.

✿ The battery plug is designed to be torsion-proof by means of a guide nose.

- If necessary, insert the battery pack (not shown).
- Insert the battery plug (9) into the battery socket (10) and push the battery plug until you hear it click into place. Then push the cables into the corresponding groove (not shown) below the plug.

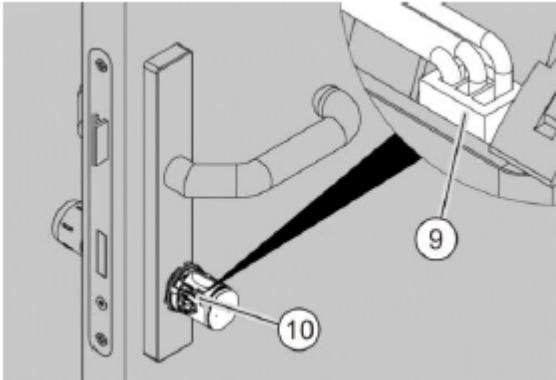

Fig. 78: Connecting the battery

- Attach the knob tool (12) to the bayonet lock. Insert the protruding pins of the knob tool (12) into the recesses of the bayonet disc (13) as shown below so that they can be twisted
- Precisely slide the knob sleeve (11) over the electronic knob. The knob sleeve (11) can only be slid on in one position because the two driving cams on the electronic knob have different widths.

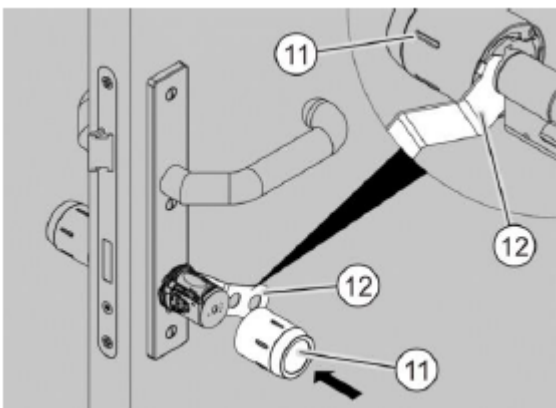

Fig. 79: Sliding on the knob sleeve

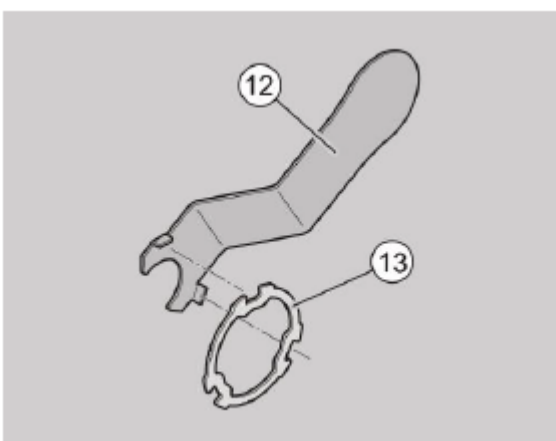

Fig. 80: Attaching the knob tool

- To lock the bayonet lock, turn the knob tool (12) clockwise.
- Ensure that the inner knob and electronic knob can be turned freely without rubbing against the handle.
- Tighten the fixing screw (5) with a Phillips screwdriver so that it is tight.

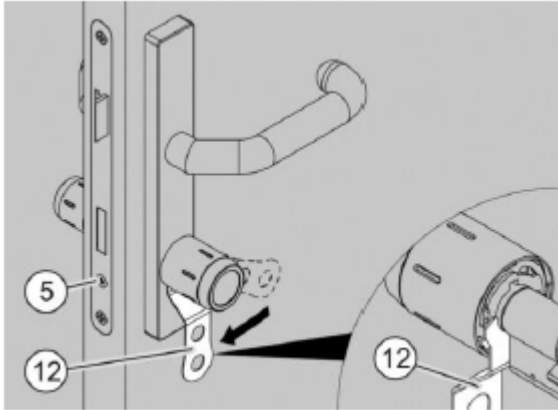

Fig. 81: Locking the bayonet lock

5.14. Assembling the EE (Emergency Exit) double cylinder that has an inner knob and reads on one side

! Serious injury or death possible as a result of the EE (Emergency Exit) cylinder not working properly
Improperly assembled or maintained handles can impair the function of escape and rescue doors in emergencies. This can result in serious or fatal injuries.

- Have the EE (Emergency Exit) cylinder assembled on escape and rescue doors by qualified personnel only.
- Additionally, observe and follow the instructions issued by the respective door, lock and handle manufacturer.
- Replace the EE (Emergency Exit) cylinder on escape and rescue doors once the maximum number of closing cycles specified on the data sheet has been reached.
- Have the maintenance work on EE (Emergency Exit) cylinders on escape and rescue doors carried out by qualified personnel only.

! The cylinder's inner knob can restrict the functionality of the panic bar (according to EN 1125) or the lever handle (according to EN 179).

- Before assembly, always ensure that there is a sufficient distance between the inner knob and the panic bar or lever handle so that the panic bar or lever handle can be operated completely and the door can be unlocked easily with a single movement.
- In any case, observe and follow the instructions issued by the respective lock and handle manufacturer.

p(banner tip).The following figure shows the installation situation with panic bar according to EN 1125. The installation situation also applies to lever handles or striking plates according to EN 179.

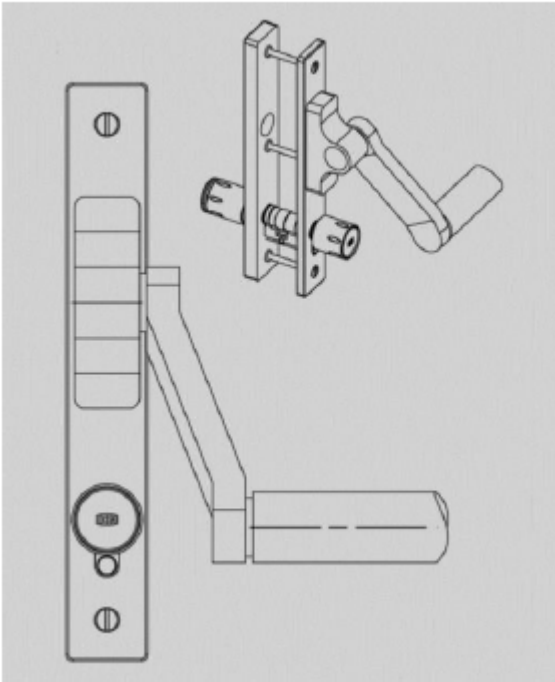

Fig. 82: Example of a panic bar

- ✿ Always assemble the cylinder with the door open so that you do not lock yourself out. The electronic knobs are engaged before initialisation when they are delivered and the cylinder's locking nose can thus be rotated.

- ✿ The following figures are schematic diagrams.

- If you use the Pro MiWE half-cylinder, check the driver's basic position before assembly. It is in the 6 o'clock position when delivered. If necessary, change the driver's basic position to the basic position required for your application (see the section Preparing for assembly from page 28 onwards). The driver is automatically returned to the set basic position once the closing process is complete.

Proceed as follows to assemble the EE (Emergency Exit) cylinder:

- Measure the door's thickness with the handle.
- Ensure that the cylinder's basic length is adapted to the measured thickness. Note the division into outside (a) and inside (b) in this regard.

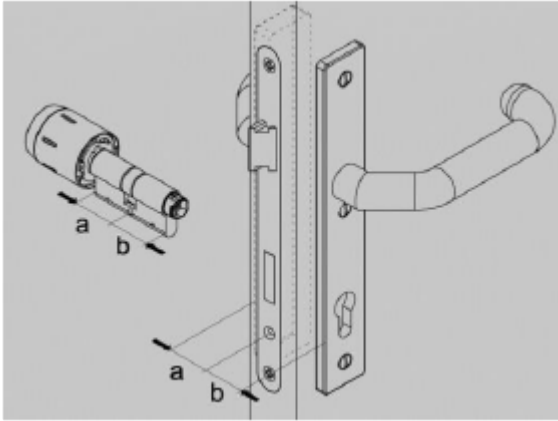

Fig. 83: Measuring the thickness

! If the cylinder protrudes more than 3 mm from the handles and rosettes, burglary protection can no longer be guaranteed.

- Always ensure that the cylinder protrudes max. 3 mm from the handles and rosettes.
- Carefully slide the cylinder (1) through the handle, door and lock from the outside.

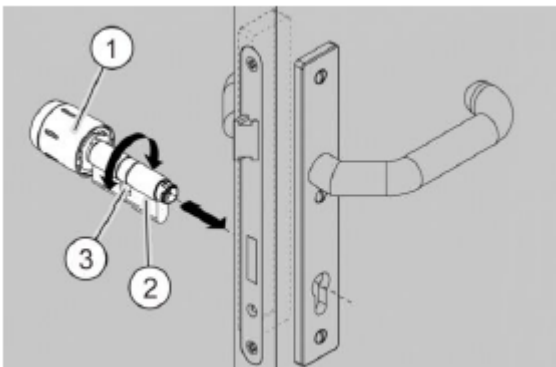

Fig. 84: Inserting the cylinder

! Damage to the cylinder caused by tightening the fixing screw or lock with a cordless screwdriver without torque limitation.

- Tighten the fixing screw with a Phillips screwdriver only so that it is hand-tight.
- Turn the already assembled rotary knob (1) or special key and pull the cylinder forwards and backwards until you have felt the correct locking nose position to drive out the lock's bolt (5).
- Leave the bolt extended until the fixing screw (4) is completely screwed into the cylinder.
- Secure the cylinder with the fixing screw (4). Do not fully tighten the fixing screw (4) yet.

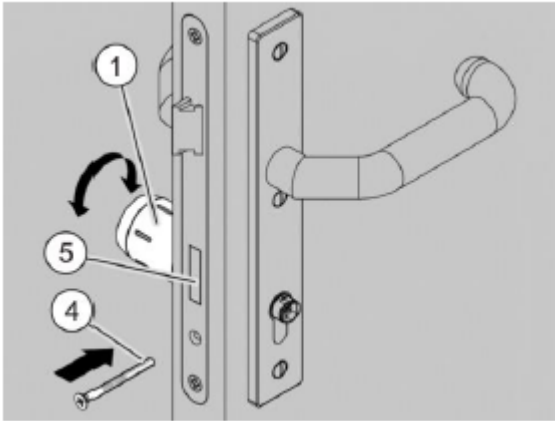

Fig. 85: Aligning the locking nose

- Precisely fit the inner knob (5) onto the cylinder's (1) coupling shaft as far as it will go. The inner knob can only be fitted in one position.

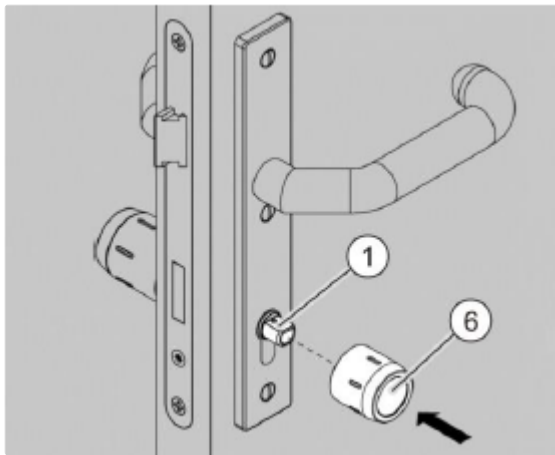

Fig. 86: Fitting the inner knob

- If necessary, turn the inner knob (6) with the coupling shaft so that the set screw (7) is easily accessible for the screwdriver.
- Tighten the M3 set screw (7) in a clockwise direction with a TORX screwdriver (T6) so that it is hand-tight (approx. 4 turns).
- Ensure that the inner knob and electronic knob can be turned freely without rubbing against the handle.
- Tighten the fixing screw (4) with a Phillips screwdriver so that it is hand-tight.

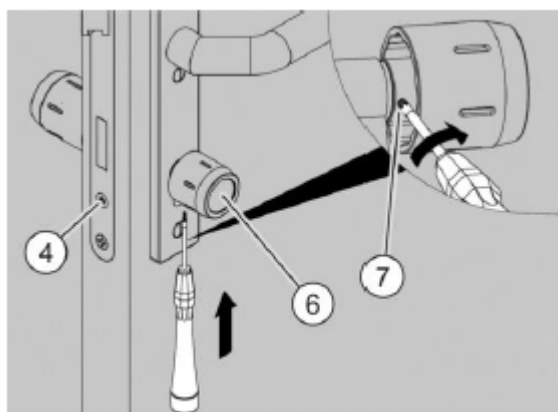

Fig. 87: Securing the inner knob

Proceed as follows if you have assembled the EE (Emergency Exit) cylinder:

- Check the escape and rescue route according to the specifications set down by the door, lock and handle manufacturer and carry out a function test as follows:
- Turn the engaged electronic knob slightly more than a quarter turn clockwise (11 o'clock or 1 o'clock position) as shown in Figs. A and B.
In both cases, the electronic knob must automatically return to the neutral position (see Fig. C).
- If the electronic knob does not turn back, realign the cylinder and inspect the lock for any defects.
- If you move the electronic knob by about half a turn, the electronic knob remains in this position (dead centre area) due to the design.
- Then ensure that the escape door lock can be safely unlocked and opened according to the specifications set down by the lock and handle manufacturer.

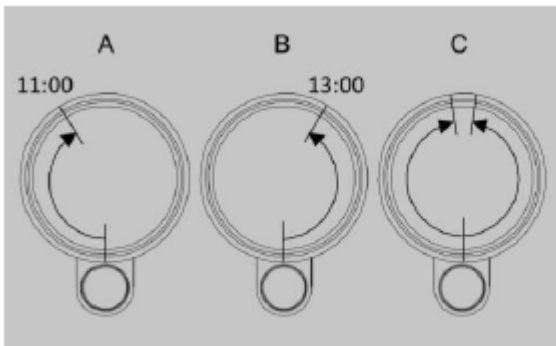

Fig. 88: Checking the function

5.15. Assembling the EE (Emergency Exit) double cylinder that has an inner knob and a core pulling protection extension (CPPE) and reads on one side

! Serious injury or death possible as a result of the EE (Emergency Exit) cylinder not working properly
Improperly assembled or maintained handles can impair the function of escape and rescue doors in emergencies. This can result in serious or fatal injuries.

- Have the EE (Emergency Exit) cylinder assembled on escape and rescue doors by qualified personnel only.
- Additionally, observe and follow the instructions issued by the respective door, lock and handle manufacturer.
- Replace the EE (Emergency Exit) cylinder on escape and rescue doors once the maximum number of closing cycles specified on the data sheet has been reached.
- Have the maintenance work on EE (Emergency Exit) cylinders on escape and rescue doors carried out by qualified personnel only.

p(banner important).The cylinder's inner knob can restrict the functionality of the panic bar (according to EN 1125) or the lever handle (according to EN 179).

- Before assembly, always ensure that there is a sufficient distance between the inner knob and the panic bar or lever handle so that the panic bar or lever handle can be operated completely and the door can be unlocked easily with a single movement.
- In any case, observe and follow the instructions issued by the respective lock and handle manufacturer.

***** The following figure shows the installation situation with panic bar according to EN 1125. The installation situation also applies to lever handles or striking plates according to EN 179.

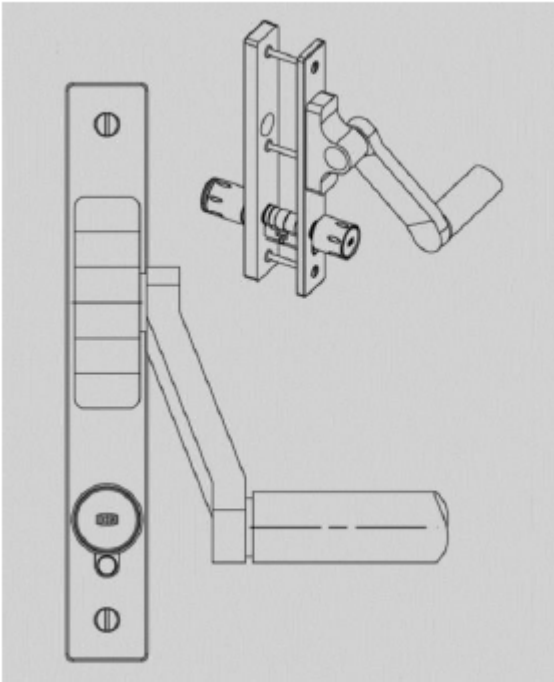

* The following describes the assembly process for protective handles or for rosettes with round holes, for which the core cover usually has to be removed before assembly. Due to the large number of handles and rosettes available on the market, the individual handles and rosettes are not shown here, and dismantling of the core cover is not described.

* The following figures are schematic diagrams.

- If you use the Pro MiWE half-cylinder, check the driver's basic position before assembly. It is in the 6 o'clock position when delivered. If necessary, change the driver's basic position to the basic position required for your application (see the section Preparing for assembly from page 28 onwards). The driver is automatically returned to the set basic position once the closing process is complete.

Proceed as follows to assemble the double cylinder:

- Measure the door's thickness with the handle.
- Ensure that the cylinder's basic length is adapted to the measured thickness. Note the division into outside (a) and inside (b) in this regard.

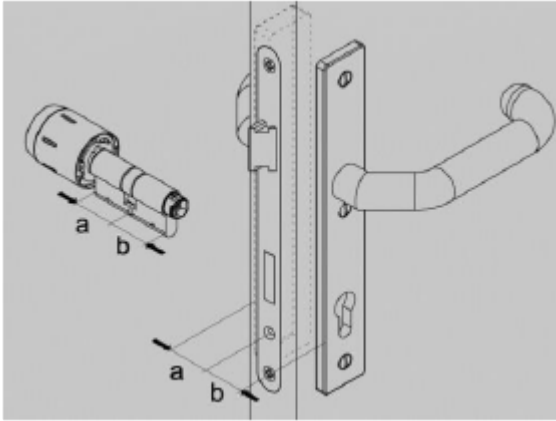

Fig. 90: Measuring the thickness

* The cylinder with the core pulling protection extension must be inserted into the installation hole from the inside to the outside. The side with the core pulling protection extension should be on the outside.

* Always assemble the cylinder with the door open so that you do not lock yourself out. The electronic knobs are engaged before initialisation when they are delivered and the cylinder's locking nose can thus be rotated.

- If it has not been assembled ex-works, precisely fit the inner knob (5) on the coupling shaft (2) as far as it will go. The inner knob can only be fitted in one position.

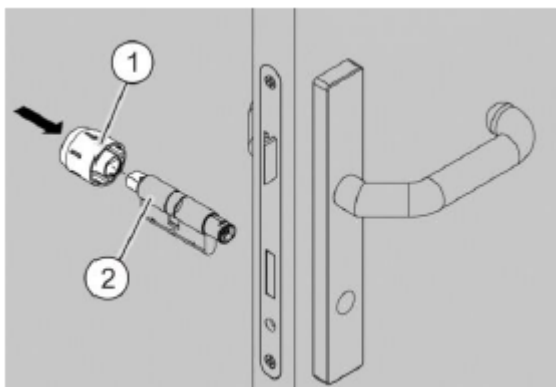

Fig. 91: Fitting the inner knob

- If necessary, turn the inner knob (1) with the coupling shaft so that the set screw (3) is easily accessible for the screwdriver.
- Tighten the M3 set screw (3) in a clockwise direction with a TORX screwdriver (T6) so that it is hand-tight (approx. 4 turns).

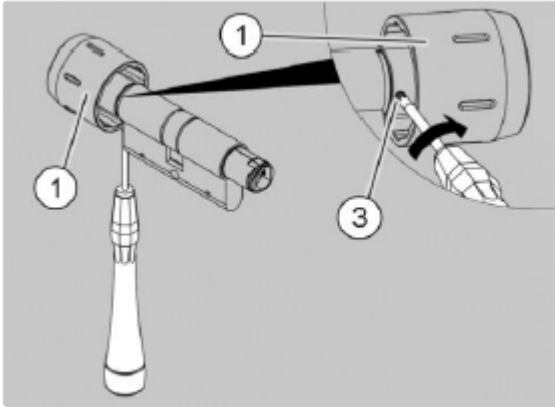

Fig. 92: Tightening the inner knob

- Carefully slide the double cylinder (2) through the handle, door and lock (4) from the inside.

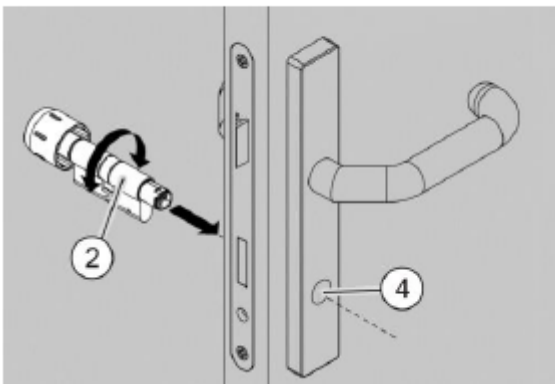

Fig. 93: Inserting the cylinder

! Damage to the cylinder caused by tightening the fixing screw or lock with a cordless screwdriver without torque limitation.

- Tighten the fixing screw with a Phillips screwdriver only so that it is hand-tight.
- Turn the already assembled rotary knob (1) or special key and pull the cylinder forwards and backwards until you have felt the correct locking nose position to drive out the lock's bolt (6).
- Leave the bolt (6) extended until the fixing screw (5) is completely screwed into the cylinder.
- Secure the double cylinder with the fixing screw (5). Do not fully tighten the fixing screw (5) yet.

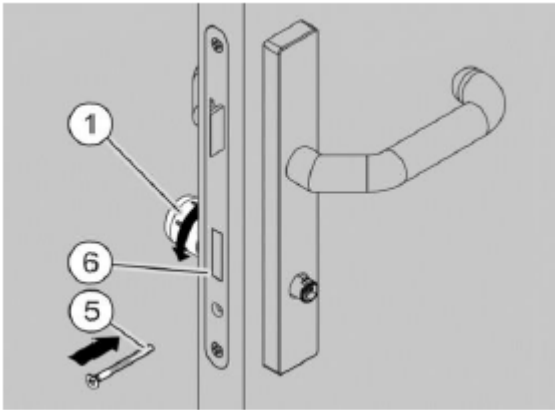

Fig. 94: Aligning the locking nose

! Risk of injury due to short-circuiting when touching the electronics.

- Always hold the electronic knob by the battery pack.

! Electrostatic discharge (sparks or flashover) can destroy electronic components.

- Therefore, before dismantling / assembling the knob sleeve, prevent electrostatic charges or touch a conductive, earthed object (e.g. a water pipe or heater) to electrostatically discharge yourself.
- If necessary, remove the knob sleeve from the electronic knob (8). If necessary, use the knob tool to carefully separate the knob sleeve from the electronic knob.
- Precisely slide the electronic knob (8) onto the coupling shaft as far as it will go. Observe the coupling shaft's and the electronic knob's groove points while doing so. The electronic knob (8) can only be guided onto the coupling shaft in one position.
- Gently push the electronic knob (8) onto the coupling shaft and secure the electronic knob (8) with the fixing bracket (7).

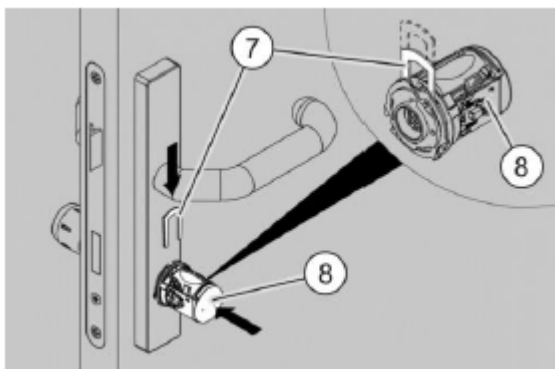

Fig. 95: Assembling the electronic knob

! If the batteries are connected before the electronic knob is assembled, the electronics may be damaged.

- First of all, ensure that the battery pack is inserted but not connected.

✿ The battery plug is designed to be torsion-proof by means of a guide nose.

- If necessary, insert the battery pack (not shown).
- Insert the battery plug (9) into the battery socket (10) and push the battery plug until you hear it click into place. Then push the cables into the corresponding groove (not shown) below the plug.

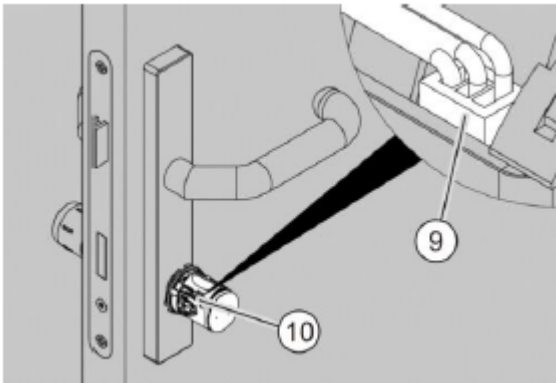

Fig. 96: Connecting the battery

- Attach the knob tool (12) to the bayonet lock. Insert the protruding pins of the knob tool (12) into the recesses of the bayonet disc (13) as shown below so that they can be twisted
- Precisely slide the knob sleeve (11) over the electronic knob. The knob sleeve (11) can only be slid on in one position because the two driving cams on the electronic knob have different widths.

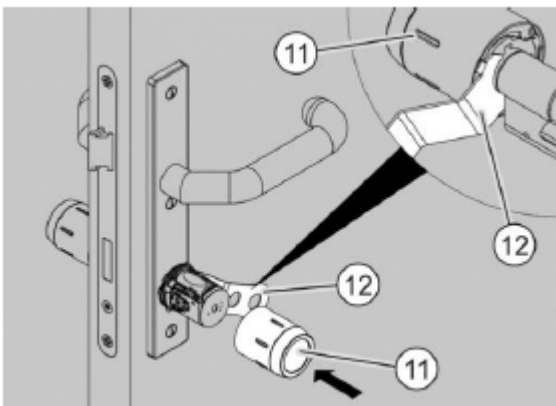

Fig. 97: Sliding on the knob sleeve

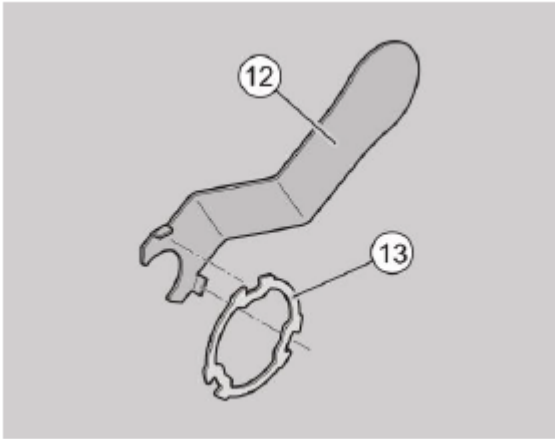

Fig. 98: Attaching the knob tool

- To lock the bayonet lock, turn the knob tool (12) clockwise.
- Ensure that the inner knob and electronic knob can be turned freely without rubbing against the handle.
- Tighten the fixing screw (5) with a Phillips screwdriver so that it is tight.

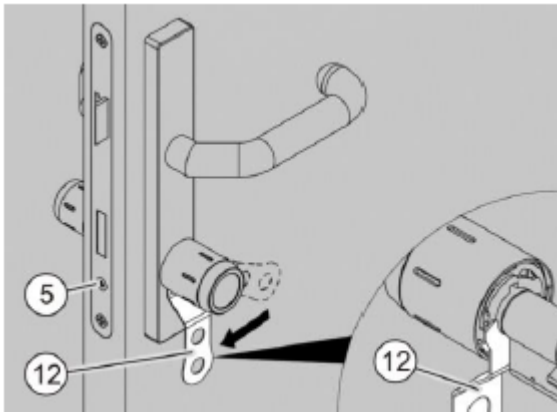

Fig. 99: Locking the bayonet lock

Proceed as follows if you have assembled the EE (Emergency Exit) cylinder:

- Check the escape and rescue route according to the specifications set down by the door, lock and handle manufacturer and carry out a function test as follows:
- Turn the engaged electronic knob slightly more than a quarter turn clockwise or anti-clockwise (11 o'clock or 1 o'clock position) as shown in Figs. A and B.
In both cases, the electronic knob must automatically return to the neutral position (see Fig. C).
- If the electronic knob does not turn back, realign the cylinder and inspect the lock for any defects.
- If you move the electronic knob by about half a turn, the electronic knob remains in this position (dead centre area) due to the design.
- Then ensure that the escape door lock can be safely unlocked and opened according to the specifications set down by the lock and handle manufacturer.

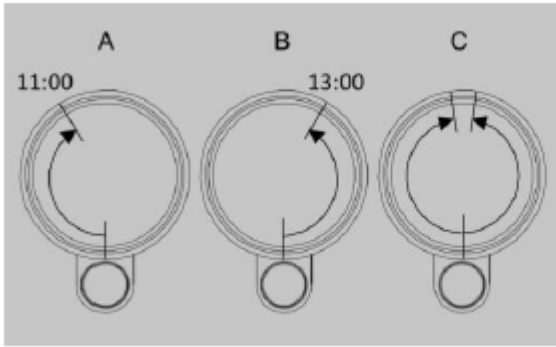

Fig. 100: Checking the function

5.16. Assembling the EE (Emergency Exit) double cylinder that has no inner knob

! Serious injury or death possible as a result of the EE (Emergency Exit) cylinder not working properly
Improperly assembled or maintained handles can impair the function of escape and rescue doors in emergencies. This can result in serious or fatal injuries.

- Have the EE (Emergency Exit) cylinder assembled on escape and rescue doors by qualified personnel only.
- Additionally, observe and follow the instructions issued by the respective door, lock and handle manufacturer.
- Replace the EE (Emergency Exit) cylinder on escape and rescue doors once the maximum number of closing cycles specified on the data sheet has been reached.
- Have the maintenance work on EE (Emergency Exit) cylinders on escape and rescue doors carried out by qualified personnel only.

* The following figure shows the installation situation with panic bar according to EN 1125. The installation situation also applies to lever handles or striking plates according to EN 179.

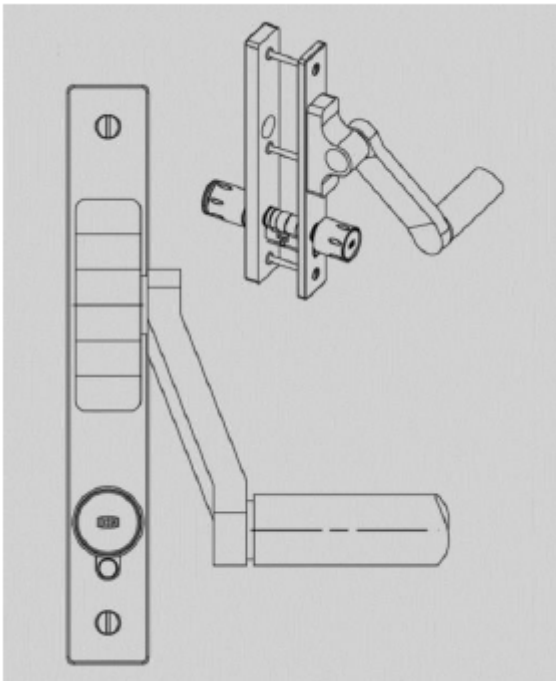

Fig. 101: Installation situation for the panic bar

* The following figures are schematic diagrams.

- If you use the Pro MiWE half-cylinder, check the driver's basic position before assembly. It is in the 6 o'clock position when delivered. If necessary, change the driver's basic position to the basic position required for your application (see the section Preparing for assembly from page 28 onwards). The driver is automatically returned to the set basic position once the closing process is complete.

Proceed as follows to assemble the cylinder:

- Measure the door's thickness with the handle.
- Ensure that the double cylinder's basic length is adapted to the measured thickness.

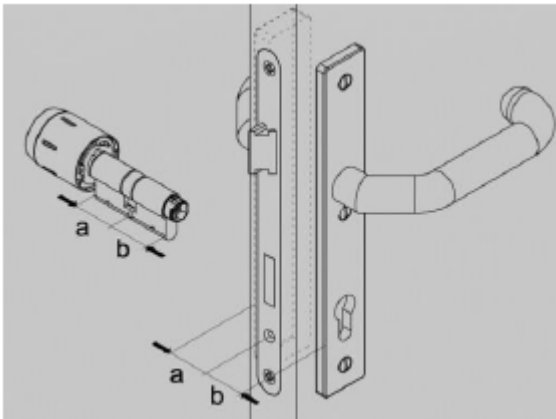

Fig. 102: Measuring the thickness

! If the cylinder protrudes more than 3 mm from the handles and rosettes, burglary protection can no longer be guaranteed.

- Always ensure that the cylinder protrudes max. 3 mm from the handles and rosettes.

! Damage to the cylinder caused by tightening the fixing screw or lock with a cordless screwdriver without torque limitation.

- Tighten the fixing screw with a Phillips screwdriver only so that it is hand-tight.
- Carefully slide the cylinder (1) through the handle, door and lock from the outside.

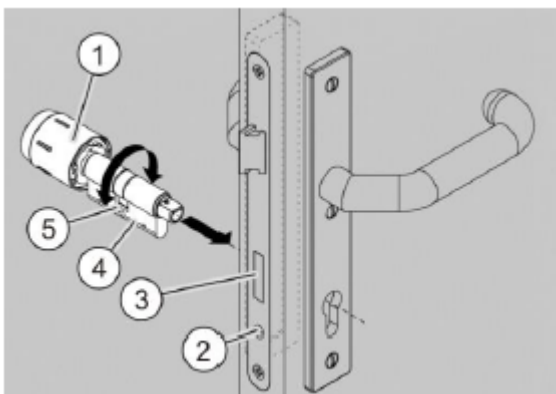

Fig. 103: Inserting the cylinder

- Turn the already assembled rotary knob (1) or special key and pull the cylinder forwards and backwards until you have felt the correct locking nose (5) position to drive out the lock's bolt (3).
- Leave the bolt (3) extended.
- Ensure that the rotary knob (1) can be turned freely without rubbing against the handle.
- Tighten the fixing screw (2) with a Phillips screwdriver so that it is hand-tight.

Proceed as follows if you have assembled the EE (Emergency Exit) cylinder:

- Check the escape and rescue route according to the specifications set down by the door, lock and handle manufacturer and carry out a function test as follows:
- Turn the engaged electronic knob slightly more than a quarter turn clockwise or anti-clockwise (11 o'clock or 1 o'clock position) as shown in Figs. A and B.
In both cases, the electronic knob must automatically return to the neutral position (see Fig. C).
- If the electronic knob does not turn back, realign the cylinder and inspect the lock for any defects.
- If you move the electronic knob by about half a turn, the electronic knob remains in this position (dead centre area) due to the design.
- Then ensure that the escape door lock can be safely unlocked and opened according to the specifications set down by the lock and handle manufacturer.

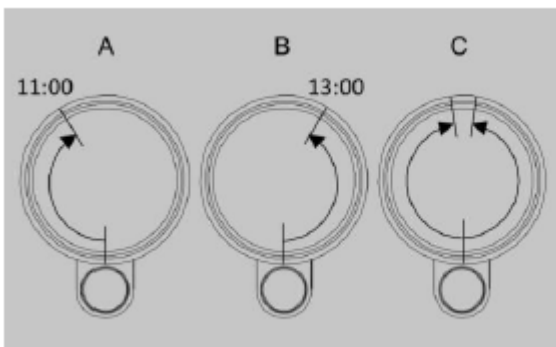

Fig. 104: Checking the function

5.17. Assembling the EE (Emergency Exit) double cylinder that has no inner knob but does have a core pulling protection extension (CPPE)

! Serious injury or death possible as a result of the EE (Emergency Exit) cylinder not working properly
Improperly assembled or maintained handles can impair the function of escape and rescue doors in emergencies. This can result in serious or fatal injuries.

- Have the EE (Emergency Exit) cylinder assembled on escape and rescue doors by qualified personnel only.
- Additionally, observe and follow the instructions issued by the respective door, lock and handle manufacturer.
- Replace the EE (Emergency Exit) cylinder on escape and rescue doors once the maximum number of closing cycles specified on the data sheet has been reached.
- Have the maintenance work on EE (Emergency Exit) cylinders on escape and rescue doors carried out by qualified personnel only.

* The following figure shows the installation situation with panic bar according to EN 1125. The installation situation also applies to lever handles or striking plates according to EN 179.

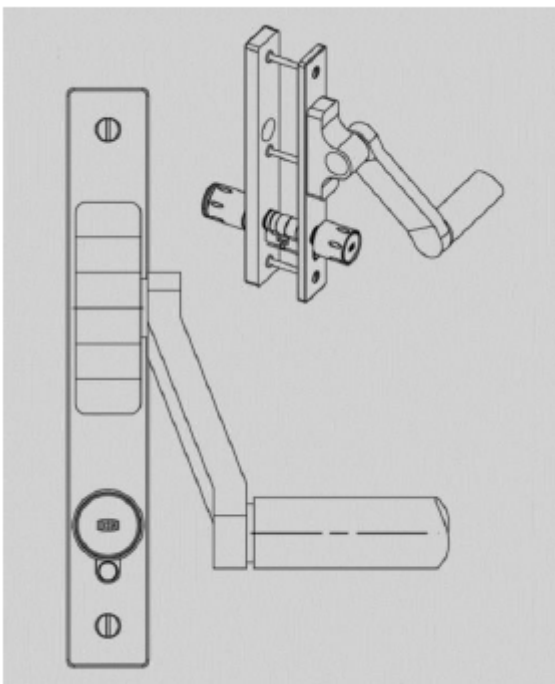

Fig. 105: Installation situation for the panic bar

- ✿ The following describes the assembly process for protective handles or for rosettes with round holes, for which the core cover usually has to be removed before assembly. Due to the large number of handles and rosettes available on the market, the individual handles and rosettes are not shown here, and dismantling of the core cover is not described.

- ✿ The following figures are schematic diagrams.

- If you use the Pro MiWE half-cylinder, check the driver's basic position before assembly. It is in the 6 o'clock position when delivered. If necessary, change the driver's basic position to the basic position required for your application (see the section Preparing for assembly from page 28 onwards). The driver is automatically returned to the set basic position once the closing process is complete.

Proceed as follows to assemble the cylinder

- Measure the door's thickness with the handle.
- Ensure that the cylinder's basic length is adapted to the measured thickness. Note the division into outside (a) and inside (b) in this regard.

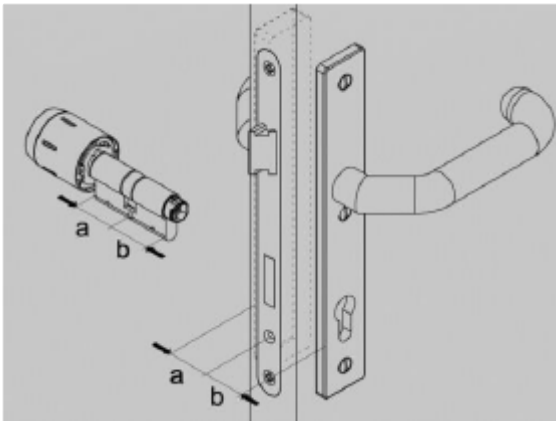

Fig. 106: Measuring the thickness

- ✿ The cylinder with the core pulling protection extension must be inserted into the installation hole from the inside to the outside. The side with the core pulling protection extension should be on the outside.

- Carefully slide the cylinder (1) through the handle, door and lock (2) from the inside.

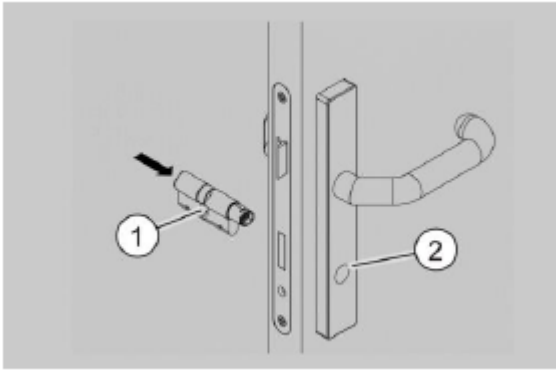

Fig. 107: Inserting the cylinder

! Damage to the cylinder caused by tightening the fixing screw or lock with a cordless screwdriver without torque limitation.

- Tighten the fixing screw with a Phillips screwdriver only so that it is hand-tight.
- Secure the double cylinder (3) with the fixing screw (4). Do not fully tighten the fixing screw (4) yet.

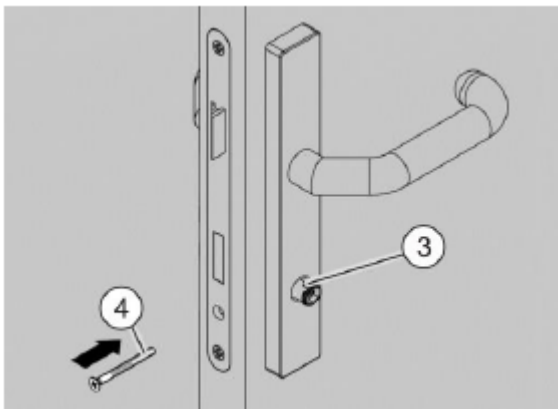

Fig. 108: Securing the cylinder

! Risk of injury due to short-circuiting when touching the electronics.

- Always hold the electronic knob by the battery pack.

! Electrostatic discharge (sparks or flashover) can destroy electronic components.

- Therefore, before dismantling / assembling the knob sleeve, prevent electrostatic charges or touch a conductive, earthed object (e.g. a water pipe or heater) to electrostatically discharge yourself.
- If necessary, remove the knob sleeve from the electronic knob (6). If necessary, use the knob tool to carefully separate the knob sleeve from the electronic knob (6).
- Precisely slide the electronic knob (6) onto the coupling shaft as far as it will go. Observe the coupling shaft's and the electronic knob's (6) groove points while doing so. The electronic knob (6)

can only be guided onto the coupling shaft in one position.

- Gently push the electronic knob (6) onto the coupling shaft and secure the electronic knob (6) with the fixing bracket (5).

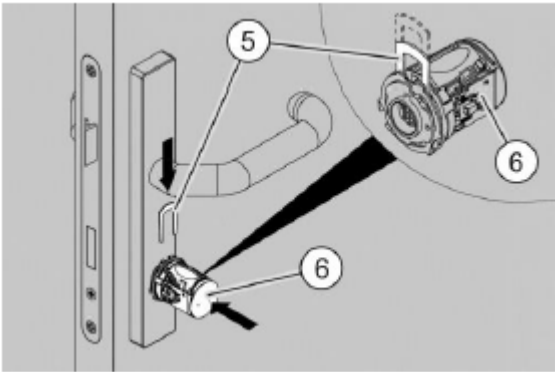

Fig. 109: Assembling the electronic knob

! If the batteries are connected before the electronic knob is assembled, the electronics may be damaged.

- First of all, ensure that the battery pack is inserted but not connected.

***** The battery plug is designed to be torsion-proof by means of a guide nose.

- If necessary, insert the battery pack into the battery socket (not shown).
- Insert the battery plug (7) into the battery socket (8) and push the battery plug until you hear it click into place. Then push the cables into the corresponding groove (not shown) below the plug.

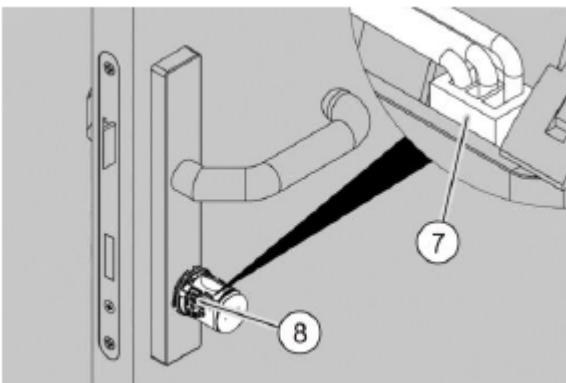

Fig. 110: Connecting the battery

- Attach the knob tool (10) to the bayonet lock. Insert the protruding pins of the knob tool into the recesses of the bayonet disc (11) as shown below so that they can be twisted.
- Precisely slide the knob sleeve (9) over the electronic knob. The knob sleeve (9) can only be slid on in one position because the two driving cams on the electronic knob have different widths.

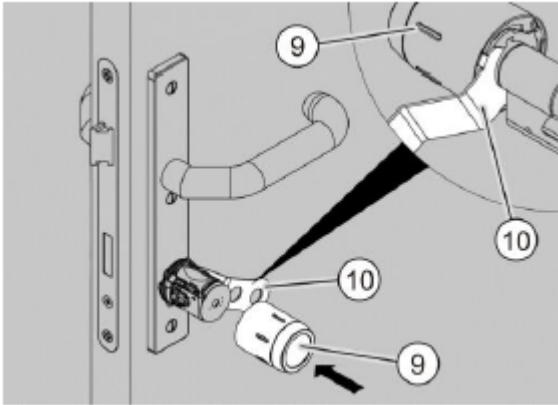

Fig. 111: Sliding on the knob sleeve

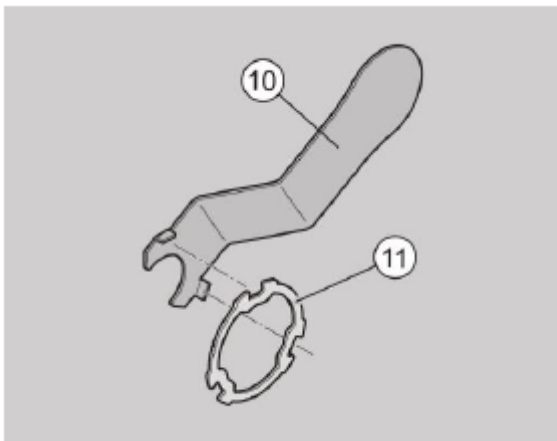

Fig. 112: Attaching the knob tool

- To lock the bayonet lock, turn the knob tool (10) clockwise.
- Ensure that the electronic knob can be turned freely without rubbing against the handle.
- Tighten the fixing screw (4) with a Phillips screwdriver so that it is hand-tight.

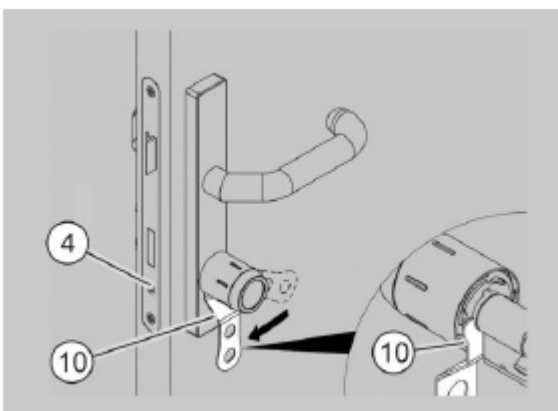

Fig. 113: Locking the bayonet lock

Proceed as follows if you have assembled the EE (Emergency Exit) cylinder:

- Check the escape and rescue route according to the specifications set down by the lock and handle manufacturer and carry out a function test as follows:
- Turn the electronic knob slightly more than a quarter turn clockwise or anti-clockwise (11 o'clock or 1 o'clock position) as shown in Figs. A and B.

In both cases, the electronic knob must automatically return to the neutral position (see Fig. C).

- If the electronic knob does not turn back, realign the cylinder and inspect the lock for any defects.
- If you move the electronic knob by about half a turn, the reading knob remains in this position (dead centre area) due to the design.
- Then ensure that the escape door lock can be safely unlocked and opened according to the specifications set down by the lock and handle manufacturer.

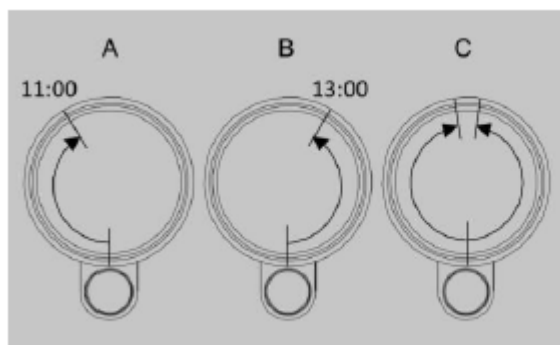

Fig. 114: Checking the function

5.18. Assembling the EE (Emergency Exit) double cylinder that has a mechanical inner key and reads on one side

! Serious injury or death possible as a result of the EE (Emergency Exit) cylinder not working properly
Improperly assembled or maintained handles can impair the function of escape and rescue doors in emergencies. This can result in serious or fatal injuries.

- Have the EE (Emergency Exit) cylinder assembled on escape and rescue doors by qualified personnel only.
- Additionally, observe and follow the instructions issued by the respective door, lock and handle manufacturer.
- Replace the EE (Emergency Exit) cylinder on escape and rescue doors once the maximum number of closing cycles specified on the data sheet has been reached.
- Have the maintenance work on EE (Emergency Exit) cylinders on escape and rescue doors carried out by qualified personnel only.

* The following figure shows the installation situation with panic bar according to EN 1125. The installation situation also applies to lever handles or striking plates according to EN 179.

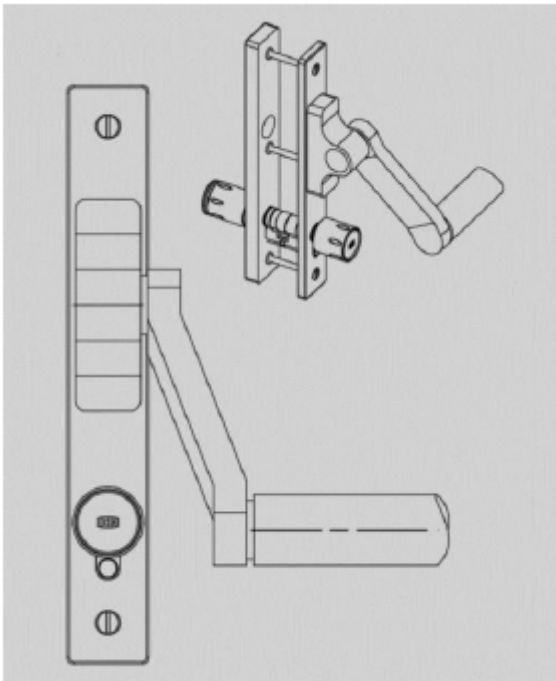

Fig. 115: Installation situation for the panic bar

* Always assemble the cylinder with the door open so that you do not lock yourself out.

The electronic knobs are engaged before initialisation when they are delivered and the cylinder's locking nose can thus be rotated.

✿ The following figures are schematic diagrams.

- If you use the Pro MiWE half-cylinder, check the driver's basic position before assembly. It is in the 6 o'clock position when delivered. If necessary, change the driver's basic position to the basic position required for your application (see the section Preparing for assembly from page 28 onwards). The driver is automatically returned to the set basic position once the closing process is complete.

Proceed as follows to assemble the EE (Emergency Exit) cylinder:

- Measure the door's thickness with the handle.
- Ensure that the cylinder's basic length is adapted to the measured thickness. Note the division into outside (a) and inside (b) in this regard.

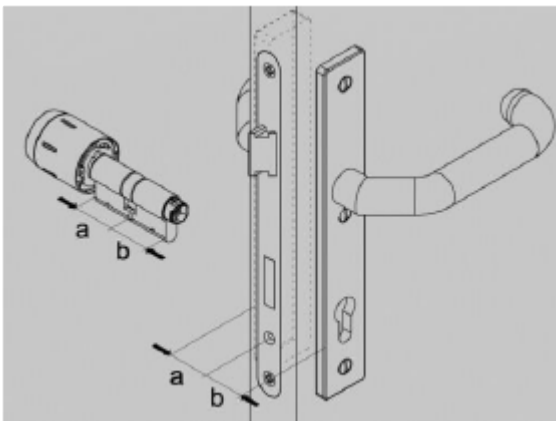

Fig. 116: Measuring the thickness

! If the cylinder protrudes more than 3 mm from the handles and rosettes, burglary protection can no longer be guaranteed.

- Always ensure that the cylinder protrudes max. 3 mm from the handles and rosettes.

! Damage to the cylinder caused by tightening the fixing screw or lock with a cordless screwdriver without torque limitation.

- Tighten the fixing screw with a Phillips screwdriver only so that it is hand-tight.
- Carefully slide the cylinder (1) through the handle, door and lock from the outside.

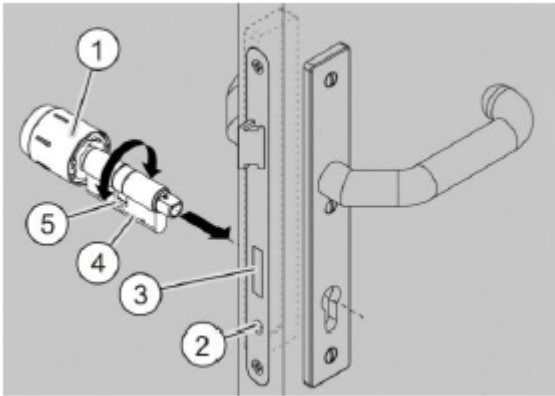

Fig. 117: Inserting the cylinder

- Turn the already assembled rotary knob (1) or special key and pull the cylinder forwards and backwards until you have felt the correct locking nose (5) position to drive out the lock's bolt (3).
- Leave the bolt (3) extended.
- Ensure that the rotary knob (1) can be turned freely without rubbing against the handle.
- Tighten the fixing screw (2) with a Phillips screwdriver so that it is hand-tight.

Proceed as follows if you have assembled the EE (Emergency Exit) cylinder:

- Check the escape and rescue route according to the specifications set down by the lock and handle manufacturer and carry out a function test as follows:
- Turn the electronic knob slightly more than a quarter turn clockwise or anti-clockwise (11 o'clock or 1 o'clock position) as shown in Figs. A and B.
In both cases, the electronic knob must automatically return to the neutral position (see Fig. C).
- If the electronic knob does not turn back, realign the cylinder and inspect the lock for any defects.
- If you move the electronic knob by about half a turn, the reading knob remains in this position (dead centre area) due to the design.
- Then ensure that the escape door lock can be safely unlocked and opened according to the specifications set down by the lock and handle manufacturer.

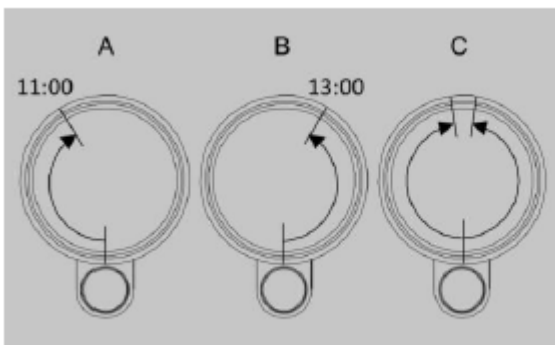

Fig. 118: Checking the function

5.19. Assembling the EE (Emergency Exit) double cylinder that has a mechanical key and a core pulling protection extension (CPPE)

! Serious injury or death possible as a result of the EE (Emergency Exit) cylinder not working properly
Improperly assembled or maintained handles can impair the function of escape and rescue doors in emergencies. This can result in serious or fatal injuries.

- Have the EE (Emergency Exit) cylinder assembled on escape and rescue doors by qualified personnel only.
- Additionally, observe and follow the instructions issued by the respective door, lock and handle manufacturer.
- Replace the EE (Emergency Exit) cylinder on escape and rescue doors once the maximum number of closing cycles specified on the data sheet has been reached.
- Have the maintenance work on EE (Emergency Exit) cylinders on escape and rescue doors carried out by qualified personnel only.

* The following figure shows the installation situation with panic bar according to EN 1125. The installation situation also applies to lever handles or striking plates according to EN 179.

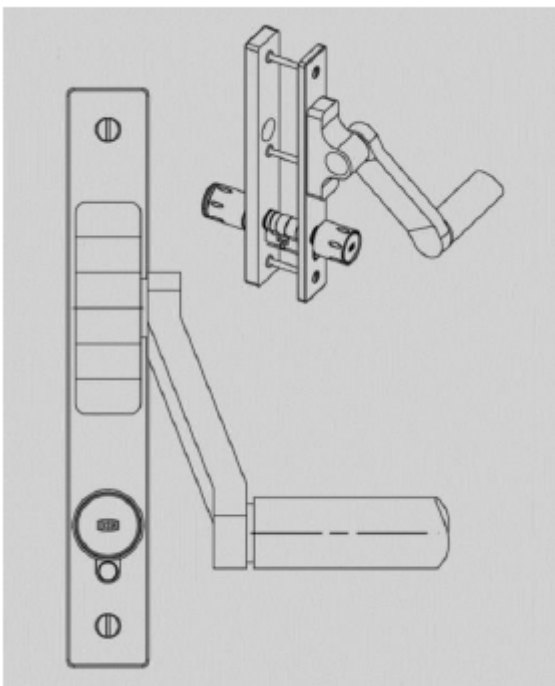

Fig. 119: Installation situation for the panic bar

- ✿ The following describes the assembly process for protective handles or for rosettes with round holes, for which the core cover usually has to be removed before assembly. Due to the large number of handles and rosettes available on the market, the individual handles and rosettes are not shown here, and dismantling of the core cover is not described.

- ✿ The following figures are schematic diagrams.

- If you use the Pro MiWE half-cylinder, check the driver's basic position before assembly. It is in the 6 o'clock position when delivered. If necessary, change the driver's basic position to the basic position required for your application (see the section Preparing for assembly from page 28 onwards). The driver is automatically returned to the set basic position once the closing process is complete.

Proceed as follows to assemble the cylinder

- Measure the door's thickness with the handle.
- Ensure that the cylinder's basic length is adapted to the measured thickness. Note the division into outside (a) and inside (b) in this regard.

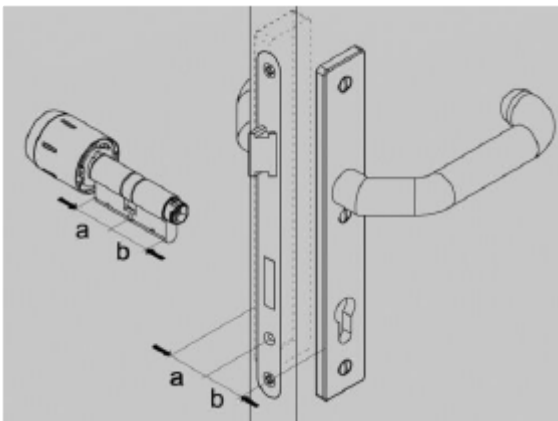

Fig. 120: Measuring the thickness

- ✿ The cylinder with the core pulling protection extension must be inserted into the installation hole from the inside to the outside. The side with the core pulling protection extension should be on the outside.

- Carefully slide the cylinder (1) through the handle, door and lock (2) from the inside.

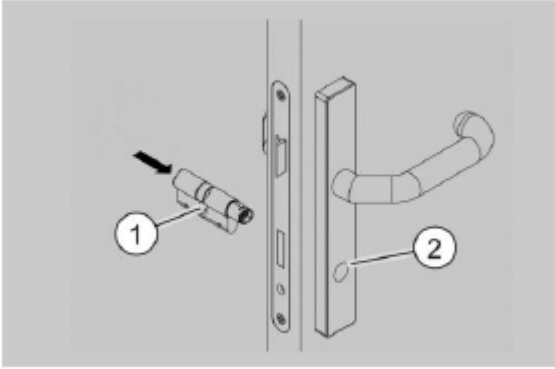

Fig. 121: Inserting the cylinder

! Risk of injury due to short-circuiting when touching the electronics.

- Always hold the electronic knob by the battery pack.

! Electrostatic discharge (sparks or flashover) can destroy electronic components.

- Therefore, before dismantling / assembling the knob sleeve, prevent electrostatic charges or touch a conductive, earthed object (e.g. a water pipe or heater) to electrostatically discharge yourself.

! Damage to the cylinder caused by tightening the fixing screw or lock with a cordless screwdriver without torque limitation.

- Tighten the fixing screw with a Phillips screwdriver only so that it is hand-tight.
- secure the double cylinder (3) with the fixing screw (4). Do not fully tighten the fixing screw (4) yet.

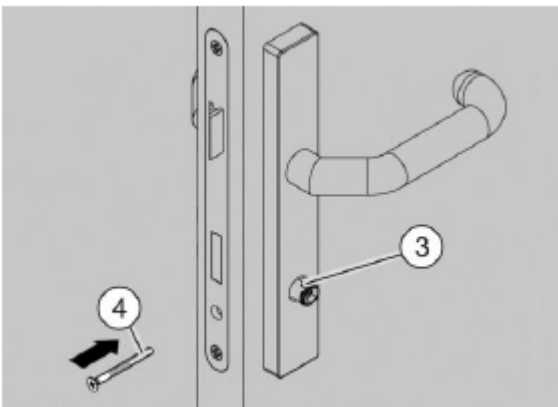

Fig. 122: Securing the cylinder

! If the batteries are connected before the electronic knob is assembled, the electronics may be damaged.

- First of all, ensure that the battery pack is inserted but not connected.

✿ The battery plug is designed to be torsion-proof by means of a guide nose.

- If necessary, remove the knob sleeve from the electronic knob (6). If necessary, use the knob tool to carefully separate the knob sleeve from the electronic knob (6).
- Precisely slide the electronic knob (6) onto the coupling shaft as far as it will go. Observe the coupling shaft's and the electronic knob's (6) groove points while doing so. The electronic knob (6) can only be guided onto the coupling shaft in one position.
- Gently push the electronic knob (6) onto the coupling shaft and secure the electronic knob (6) with the fixing bracket (5).

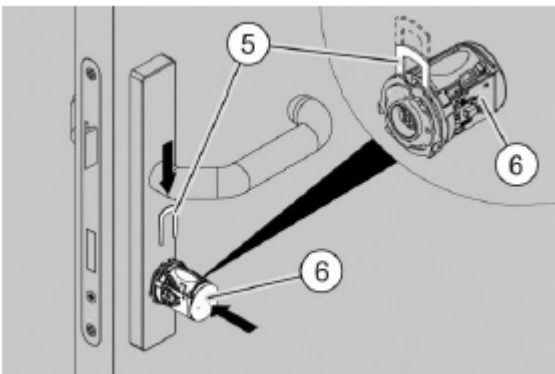

Fig. 123: Assembling the electronic knob

- If necessary, insert the battery pack into the battery socket (not shown).
- Insert the battery plug (7) into the battery socket (8) and push the battery plug until you hear it click into place. Then push the cables into the corresponding groove (not shown) below the plug.

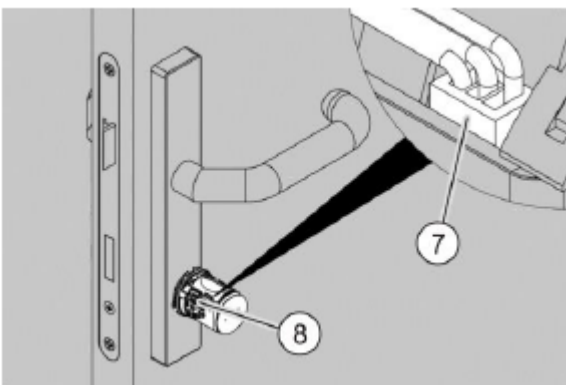

Fig. 124: Connecting the battery

- Attach the knob tool (10) to the bayonet lock. Insert the protruding pins of the knob tool into the recesses of the bayonet disc (11) as shown below so that they can be twisted.
- Precisely slide the knob sleeve (9) over the electronic knob. The knob sleeve (9) can only be slid on in one position because the two driving cams on the electronic knob have different widths.

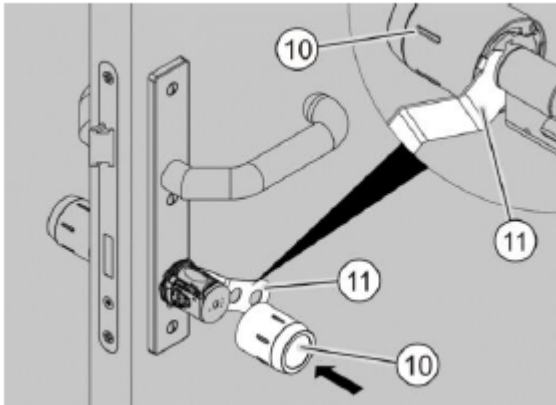

Fig. 125: Sliding on the knob sleeve

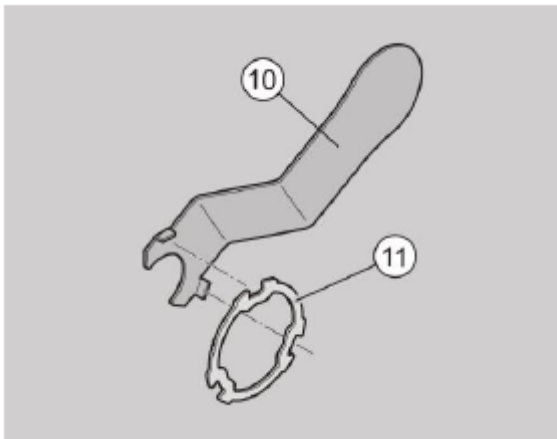

Fig. 126: Attaching the knob tool

- To lock the bayonet lock, turn the knob tool (10) clockwise.
- Ensure that the electronic knob can be turned freely without rubbing against the handle.
- Tighten the fixing screw (4) with a Phillips screwdriver so that it is hand-tight.

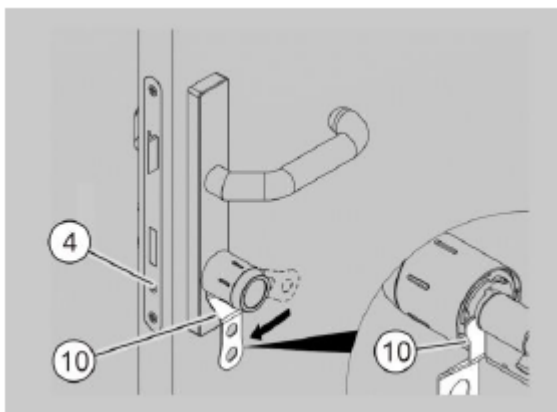

Fig. 127: Locking the bayonet lock

Proceed as follows if you have assembled the EE (Emergency Exit) cylinder:

- Check the escape and rescue route according to the specifications set down by the lock and handle manufacturer and carry out a function test as follows:
- Turn the electronic knob slightly more than a quarter turn clockwise or anti-clockwise (11 o'clock

or 1 o'clock position) as shown in Figs. A and B.

In both cases, the electronic knob must automatically return to the neutral position (see Fig. C).

- If the electronic knob does not turn back, realign the cylinder and inspect the lock for any defects.
- If you move the electronic knob by about half a turn, the reading knob remains in this position (dead centre area) due to the design.
- Then ensure that the escape door lock can be safely unlocked and opened according to the specifications set down by the lock and handle manufacturer.

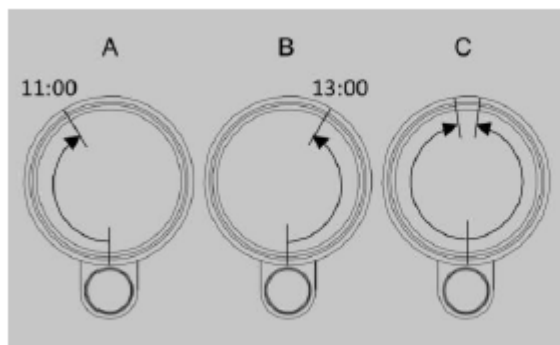

Fig. 128: Checking the function

5.20. Assembling the half-cylinder with M4 holes

The half-cylinder is assembled from the outside. Proceed as follows to assemble it:

- Measure the door's thickness with the lock.
- Ensure that the half-cylinder's basic length is adapted to the measured thickness.

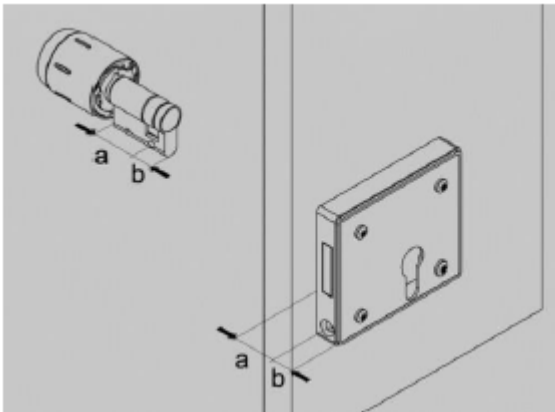

Fig. 129: Measuring the thickness

- Position the locking nose (2) so that it is flush with the cylinder (1).
- Carefully slide the cylinder (1) into the lock or switch.
- Turn the electronic knob (3) on the outside to the left or right until the locking nose (2) is positioned correctly for the function.

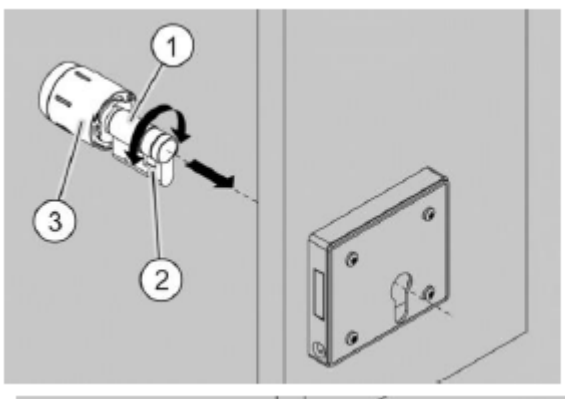

Fig. 130: Aligning the locking nose

! Damage to the cylinder caused by tightening the fixing screw or lock with a cordless screwdriver without torque limitation.

- Tighten the fixing screw with a Phillips screwdriver only so that it is hand-tight.
- Ensure that the electronic knob (3) can be turned freely without rubbing against the surface

underneath.

- Tighten the fixing screw (4) so that it is hand-tight.

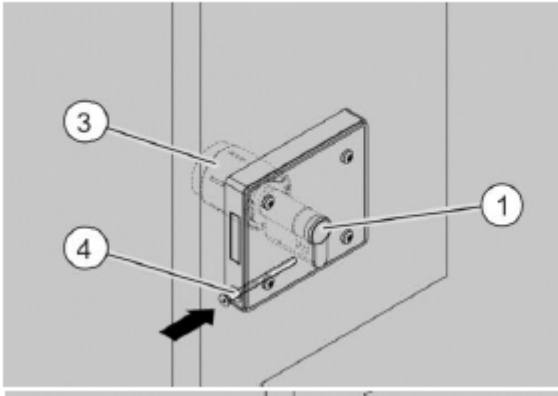

Fig. 131: Securing the cylinder

5.21. Assembling the half-cylinder with a core pulling protection extension (CPPE)

- * The following describes the assembly process for protective handles or for rosettes with round holes, for which the core cover usually has to be removed before assembly. Due to the large number of handles and rosettes available on the market, the individual handles and rosettes are not shown here, and dismantling of the core cover is not described.

- * The following figures are schematic diagrams.

Proceed as follows to assemble the half-cylinder:

- Measure the door's thickness with the lock.
- Ensure that the cylinder's basic length is adapted to the measured thickness. Note the division into outside (a) and inside (b) in this regard.

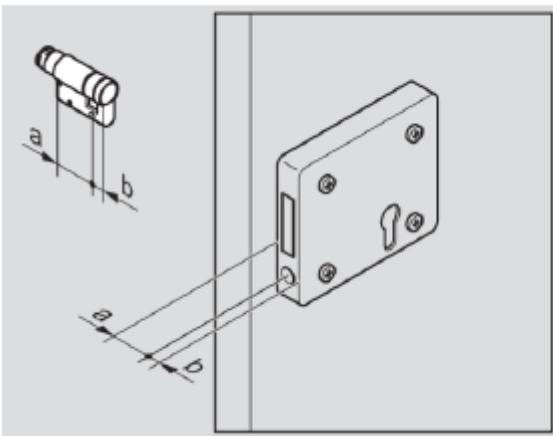

Fig. 132: Measuring the thickness

- * The half-cylinder with a core pulling protection extension must be inserted into the installation hole from the inside to the outside. The side with the core pulling protection extension should be on the outside.

- Position the locking nose (1) so that it is flush with the cylinder body (2).
- Slide the half-cylinder into the lock as shown and hold it tight with one hand.

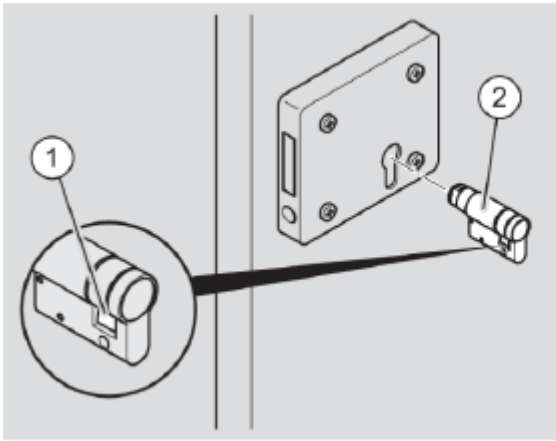

Fig. 133: Inserting the cylinder

! Risk of injury due to short-circuiting when touching the electronics.

- Always hold the electronic knob by the battery pack.

! Electrostatic discharge (sparks or flashover) can destroy electronic components.

- Therefore, before dismantling / assembling the knob sleeve, prevent electrostatic charges or touch a conductive, earthed object (e.g. a water pipe or heater) to electrostatically discharge yourself.

! If the batteries are connected before the electronic knob is assembled, the electronics may be damaged.

- First of all, ensure that the battery pack is inserted but not connected.

***** The battery plug is designed to be torsion-proof by means of a guide nose.

- If necessary, remove the knob sleeve from the electronic knob (4). If necessary, use the knob tool to carefully separate the knob sleeve from the electronic knob (4).
- Precisely slide the electronic knob (4) onto the coupling shaft as far as it will go (3). Observe the coupling shaft's and the electronic knob's groove points while doing so. The electronic knob (4) can only be guided onto the coupling shaft (3) in one position.
- Gently push the electronic knob (4) onto the coupling shaft (3) and secure the electronic knob (4) with the fixing bracket (5).

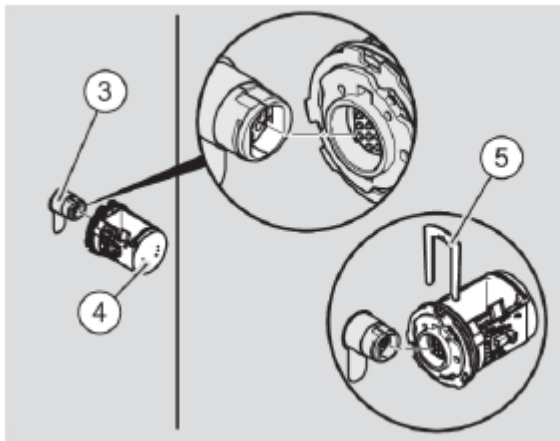

Fig. 134: Assembling the electronic knob

- Insert the battery pack (6) if necessary.
- Insert the battery plug (7) into the battery socket (8) and push the battery plug (7) until you hear it click into place. Then push the cables into the corresponding groove (not shown) below the plug.

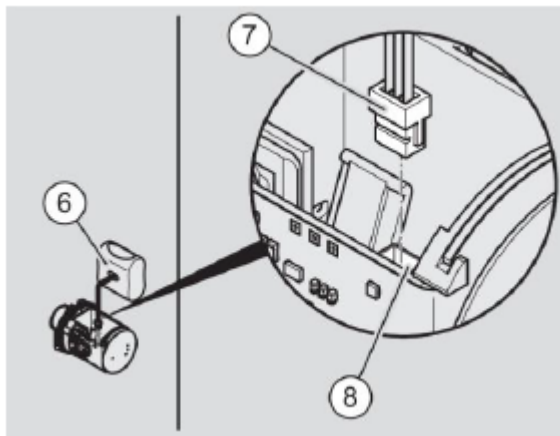

Fig. 135: Connecting the battery

- Attach the knob tool (9) to the bayonet lock. Insert the protruding pins of the knob tool (9) into the recesses of the bayonet disc (10) so that they can be twisted.

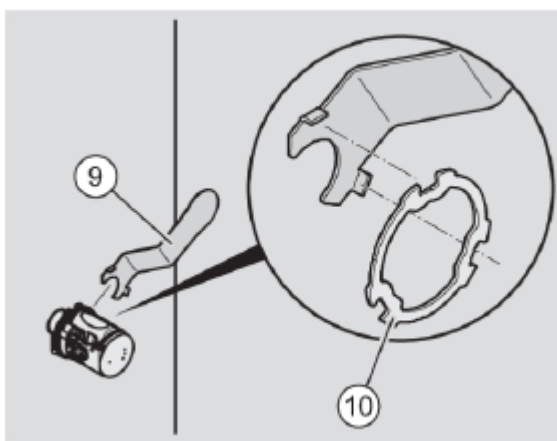

Fig. 136: Sliding on the knob sleeve

- Precisely slide the knob sleeve (11) over the electronic knob. The knob sleeve (11) can only be slid on in one position because the two driving cams on the electronic knob have different widths.

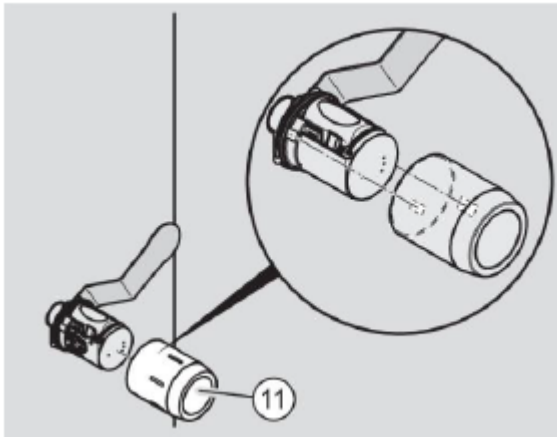

Fig. 137: Pushing on the knob sleeve

- To lock the bayonet lock, turn the knob tool clockwise.

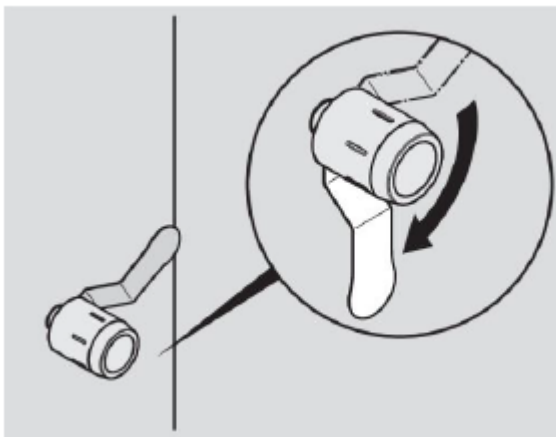

Fig. 138: Locking the bayonet lock

! Damage to the cylinder caused by tightening the fixing screw or lock with a cordless screwdriver without torque limitation.

- Tighten the fixing screw with a Phillips screwdriver only so that it is hand-tight.
- Turn the electronic knob (11) on the outside to the left or right until the locking nose is positioned correctly for the function.
- Ensure that the electronic knob (11) can be turned freely without rubbing against the surface underneath.
- Tighten the fixing screw (12) so that it is hand-tight.

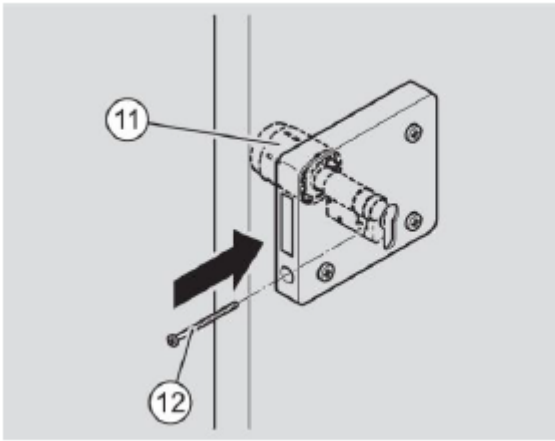

Fig. 139: Securing the cylinder

5.22. Assembling the half-cylinder with M4 holes

* The following figures are schematic diagrams.

Proceed as follows to assemble the M4 half-cylinder:

- Measure the thickness of the control panel with the lift control panel box.
- Ensure that the half-cylinder's basic length is adapted to the measured thickness.

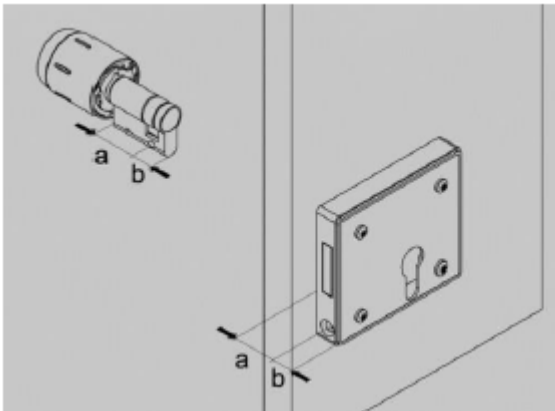

Fig. 140: Measuring the thickness

- Position the locking nose (3) so that it is flush.
- Carefully slide the half-cylinder into the control panel's box (1).
- Secure the half-cylinder on the inside with at least one screw (M4). Do not fully tighten the screw (2) yet.
- Ensure that the electronic knob can be turned freely without rubbing against the control panel.
- Tighten the screw (2) so that it is hand-tight.

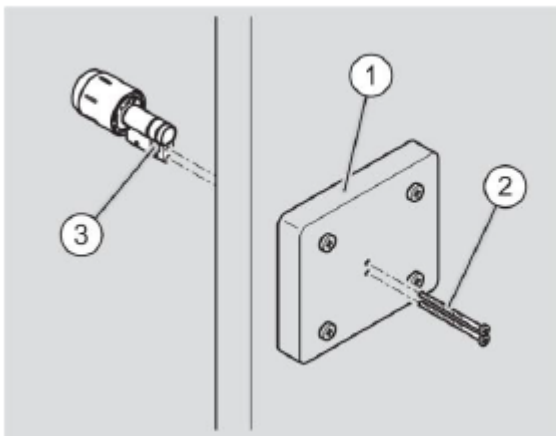

Fig. 141: Assembling the cylinder

5.23. Assembling the half-cylinder for swivelling lever handles

Proceed as follows to assemble the half-cylinder (1) with a predefined locking nose position in the swivel lever handle:

- Open the swivel lever handle (2).
- Place the locking nose (3) so that it is flush with the cylinder and hold it in this position.
- Slide the half-cylinder (1) through the swivel lever handle (2).

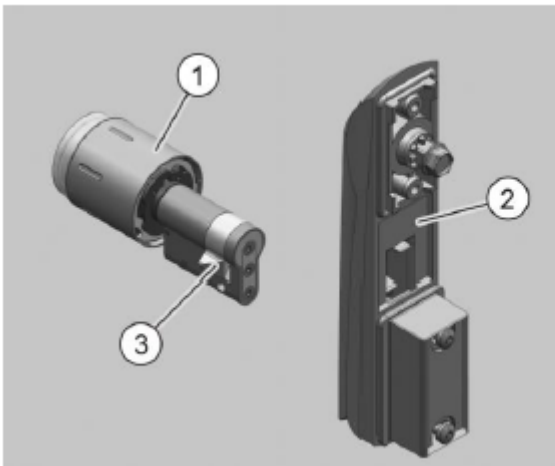

Fig. 142: Aligning the locking nose

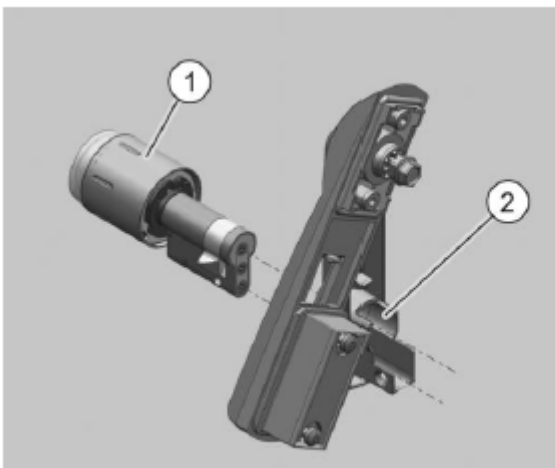

Fig. 143: Inserting the cylinder

- Secure the cylinder (1) in the swivel lever handle (2) with the fixing screw (4).

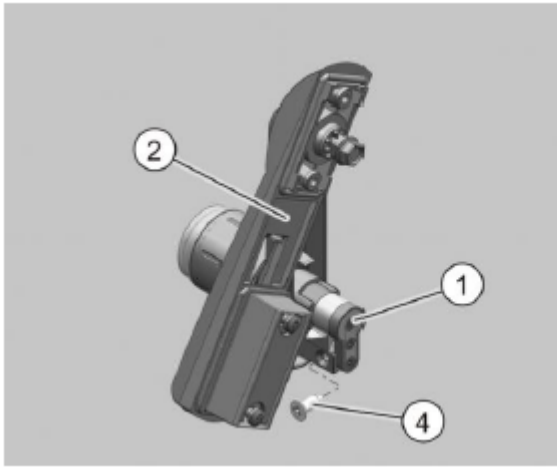

Fig. 144: Securing the cylinder

5.24. Assembling the lever cylinder

! Risk of eye injuries through drilling dust.

- Wear safety goggles.
- Use equipment to extract the drilling dust.

! Risk of finger or hand injuries caused by slipping during drilling or screwing work.

- Wear suitable safety gloves.
- Observe and follow the notices provided in the drilling machine documentation when drilling.

The lever cylinder can be installed in letterbox doors with a door leaf of max. 25 mm, for example. Proceed as follows to assemble the lever cylinder:

- Drill the installation hole (4) if necessary.
If the installation hole (4) is to be larger, you must prepare the door with an optional retaining plate (1). Proceed as follows in this regard:
 - Drill the screw connection points (3) as required for the retaining plate.
 - Attach the retaining plate (1) to the installation hole (4) as shown and secure it with two screws (2).
- Remove the chips and drilling dust if necessary.

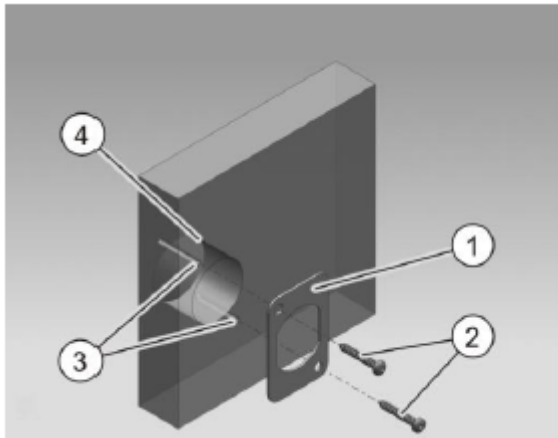

Fig. 145: Preparing the door with a retaining plate

* A retaining plate may only be required for wooden doors.

- Carefully slide the lever cylinder (5) through the installation hole from the outside.

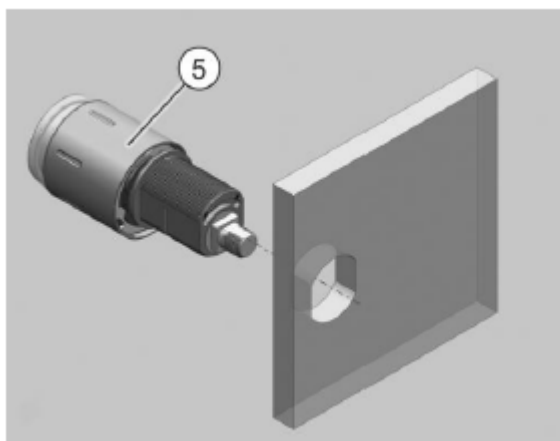

Fig. 146: Inserting the cylinder

- Secure the lever cylinder with the supplied hexagon nut (6) WAF 30.

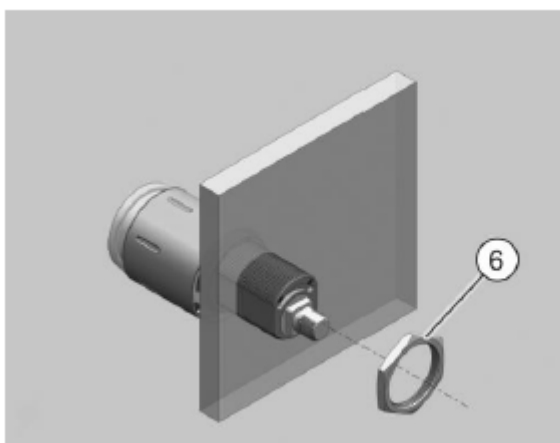

Fig. 147: Securing the cylinder with the hexagon nut

- Add the lever travel limiter (8) so that the limiter pin engages in the cylinder body's groove (7).

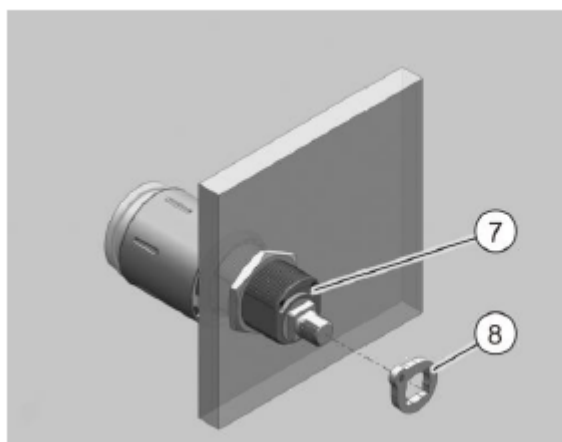

Fig. 148: Attaching the lever travel limiter

* The lever travel limiter limits the lever travel to a rotation of up to 90°.

* The lever travel limiter determines the cylinder's locking direction in conjunction with the lever.

- Use the lever travel limiter to determine the lever cylinder's locking direction (left B, right A).

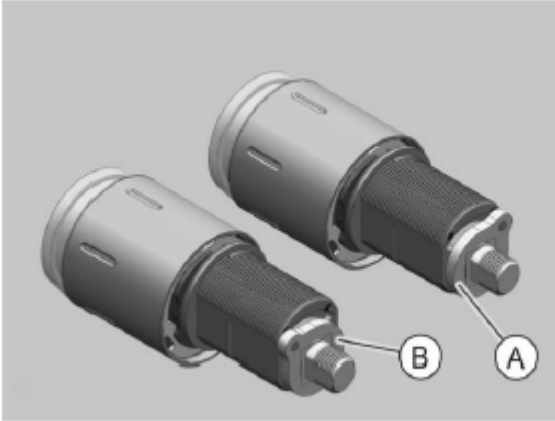

Fig. 149: Setting the lock direction

- Select the lever perforation and position required for the installation situation. The supplied lever, perforated lengthwise and crosswise, allows you to choose from four positions.

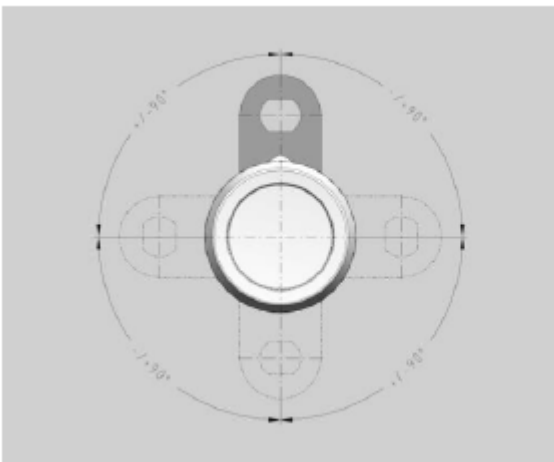

Fig. 150: Selecting the lever perforations

* We stock levers with different lengths, offsets and hooks for you. Contact your specialist dealer if the supplied lever does not fit in your installation situation.

- Place the lever (9) in the required position on the rear of the cylinder body (7).

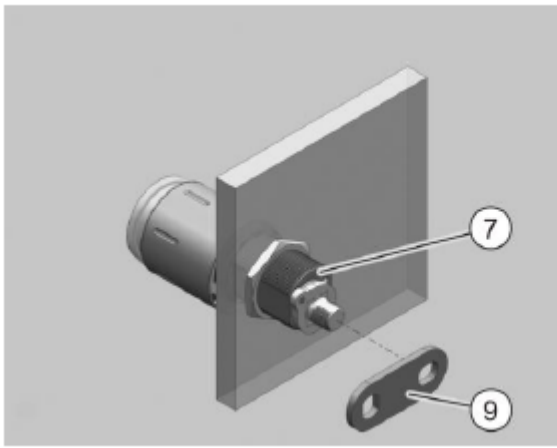

Fig. 151: Attaching the lever

- Secure the levers (9) one after the other with the supplied hexagon nuts (10) WAF 14. Tighten the hexagon nuts (9) with a little force.

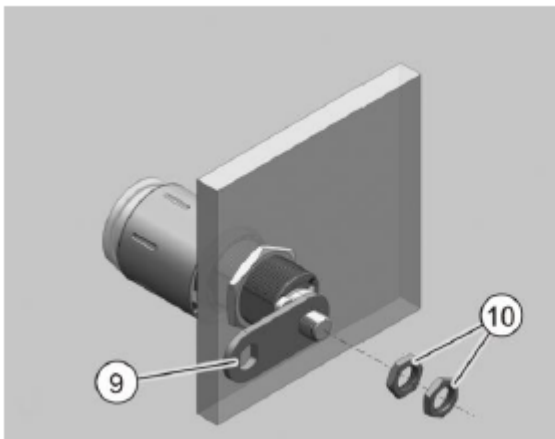

Fig. 152: Securing the lever



Fig. 153: Final assembly condition

5.25. Assembling the Scandinavian round cylinder that reads on one side

* The following figure is a schematic diagram.

Only the outer cylinder (1) is included in the scope of delivery for the Scandinavian round cylinder. This outer cylinder must be replaced with the existing outer cylinder. Proceed as follows in this regard:

- Loosen the screws (3) on the inside and set them to the side.
- Remove the existing cylinder including the driver on the outside (not shown).
- First of all, insert the driver (not shown) secured to the rear of the outer cylinder (1) from the outside into the perforation in the lock provided for this purpose. Then slide it through the handle with the entire outer cylinder (1).
- Secure the outer cylinder (1) on the inside along with the existing cylinder (2) using four screws (3).

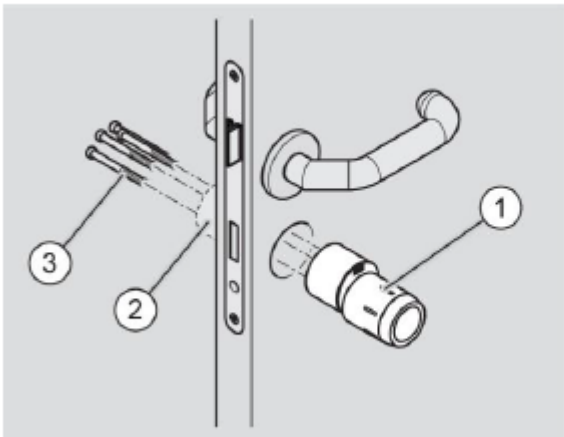

Fig. 154: Assembling the cylinder

5.26. Assembling the Scandinavian oval cylinder that reads on one side

* The following figure is a schematic diagram.

Only the outer cylinder (1) is included in the scope of delivery for the Scandinavian oval cylinder. This outer cylinder must be replaced with the existing outer cylinder. Proceed as follows in this regard:

- Loosen the screws (3) on the inside and set them to the side.
- Remove the existing cylinder including the driver on the outside (not shown).
- First of all, insert the driver (not shown) secured to the rear of the outer cylinder (1) from the outside into the perforation in the lock provided for this purpose. Then slide it through the handle with the entire outer cylinder (1).
- Secure the outer cylinder (1) on the inside along with the existing cylinder (2) using two screws (3).

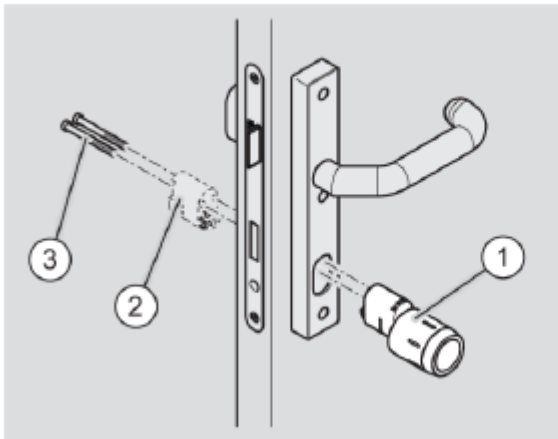

Fig. 155: Assembling the cylinder

6. Putting the cylinder into operation

* The sections below describe the process of putting the cylinders in the ENiQ and ELS system families into operation for the first time. The cylinders in the DOM Tapkey system families can be put into operation with the Tapkey app. Download the DOM Tapkey app for this purpose and follow the instructions in the app.

The cylinders in the ENiQ and ELS system families can be initialised, i.e. assigned to an object or a system, shortly before installation or after assembly. Initial commissioning with a master card is described below. For more information about initialisation and operation, refer to the relevant instructions for the management product that you want to operate / manage the system with.

* You only need the master card to be able to put the cylinder into operation without using any software. You use it to create affiliation with the system. From this moment on, programming on the terminal device can only be carried out from this master card or from programming cards / software products authorised with this master card. Thus, only the owner of the master card decides on allocations and the assignment of permissions.

- Keep the master card in a safe place that only authorised people have access to.
The master card does not have a closing device function!
- Contact your dealer if the master card is lost.
Complex reprogramming of the cylinders by the manufacturer is necessary; this also requires proof of ownership for the cylinders.

* Programming with the master card and the programming card is carried out once at each reading knob. Only perform programming when the door is open, so that you do not lock yourself out.

6.1. Initialising the cylinder

Proceed as follows to initialise the cylinder:

- Briefly hold the master card in front of the respective electronic knob.
The yellow LEDs light up once for a long time. Then the electronic knob signals its initialisation by means of the short red, green, yellow and blue signal sequence and then by the long yellow signal sequence. The electronic knob restarts following successful initialisation. The electronic knob can then be programmed with the master card, programming card or software and app products.

 If the double cylinder that reads on both sides is assembled, programming on each electronic knob is independent. The closing devices' permission can be programmed differently on both sides.

- If the cylinder reads from both sides, repeat the procedure on the other electronic knob.

6.2. Creating a transponder

- * The cylinder automatically detects transponders when they approach the electronic knob's reading field. In rare cases, environmental influences in the form of interference fields or the use of transponders that are not approved by DOM Sicherheitstechnik can lead to transponders not being recognised.

The figure below shows the electronic knob's reading field (1).

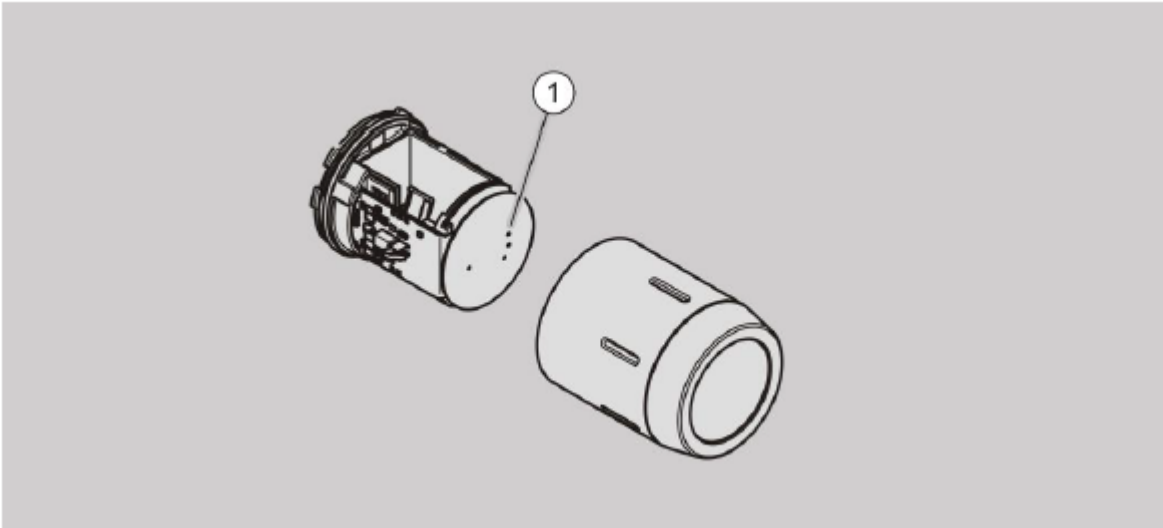

Fig. 156: The electronic knob's reading field

Proceed as follows to create the transponder:

- Hold the master card in front of the respective electronic knob.
The LEDs light up blue once for a long time.
- Hold the master card in front of the respective electronic knob again.
The LEDs briefly light up green. The master card is accepted.
- Briefly and individually hold each transponder directly in front of the respective electronic knob and wait for the signalisation.
The LEDs each briefly light up green. Addition of the transponder is signalled. Programming is completed after approx. five seconds (time-out) or by showing the master card (MID) again. The LEDs light up blue for a long time.

7. Maintaining the cylinder

7.1. Changing batteries

The power supply for the cylinder and the padlock is provided by a battery pack (pack of 2 CR2 batteries). The batteries need to be changed once the battery warning has been issued.

The power supply for the cylinder that reads on both sides is provided by two battery packs (pack of 2 CR2 batteries). A battery warning is issued on both sides independently of one another.

The cylinder is equipped with a three-level warning system.

Battery warning level 1

If the batteries will run flat soon, battery warning level 1 will be displayed as soon as you hold a transponder to the electronic knob. At battery warning level 1, all four LEDs light up as follows:

- All LEDs light up yellow for a long time
- All LEDs briefly light up red
- All LEDs briefly light up yellow
- All LEDs briefly light up red
- All LEDs briefly light up yellow
- All LEDs briefly light up red
- All LEDs light up yellow for a long time



Fig. 157: Indicators at battery warning level 1

The LEDs then briefly light up green one after the other. You can open the door or padlock and operate the electronic knob about 1,000 more times.

- Inform the responsible person that the cylinder's or padlock's batteries have to be replaced.

Battery warning level 2

If the batteries will run flat shortly, battery warning level 2 will be displayed as soon as you hold a transponder to the electronic knob. At battery warning level 2, all four LEDs light up as follows:

- All LEDs light up yellow for a long time
- All LEDs briefly light up red
- All LEDs briefly light up yellow
- All LEDs briefly light up red
- All LEDs briefly light up yellow
- All LEDs briefly light up red
- All LEDs light up yellow for a long time
- All the LEDs light up yellow for a long time for a second time



Fig. 158: Battery warning level 2 indicators

To be able to open the door or padlock, you must hold the transponder to the electronic knob a second

time.

- Hold the transponder to the electronic knob.
The LEDs briefly light up green one after the other. You can open the door or padlock and operate the electronic knob about 500 more times.
- Inform the responsible person that the cylinder's or padlock's batteries have to be replaced.

Battery warning level 3

When the batteries are almost flat, battery warning level 3 will be displayed as soon as you hold a transponder to the electronic knob. At battery warning level 3, all four LEDs light up as follows:

- All LEDs light up yellow for a long time
- All LEDs briefly light up red
- All LEDs briefly light up yellow
- All LEDs briefly light up red
- All LEDs briefly light up yellow
- All LEDs briefly light up red
- All LEDs light up yellow for a long time three times



Fig. 159: Indicators at battery warning level 3

The door or padlock does not open.

- Ensure that the respective cylinder's or padlock's batteries are replaced as quickly as possible. In an emergency, the door or padlock can only be opened by holding the master card in front of it once.

7.1.1. Changing the cylinder's battery pack

Proceed as follows to change the cylinder's battery pack:

- To unlock the bayonet lock, place the pins of the knob tool (2) in the recesses of the bayonet disc (3) as shown below.
- Turn the bayonet disc (3) anti-clockwise with the knob tool (2).
- Carefully pull off the knob sleeve (1).

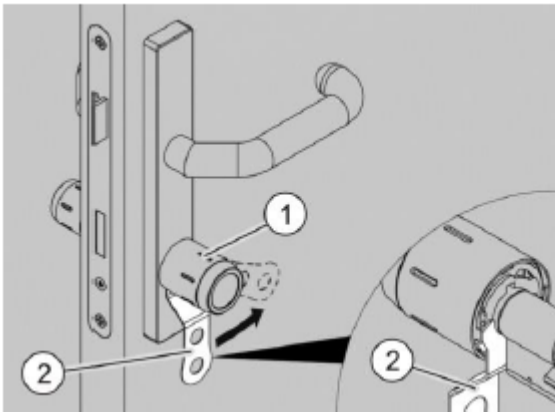

Fig. 160: Unlocking the bayonet lock

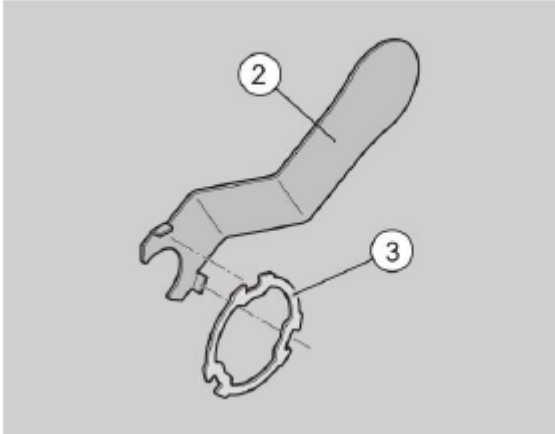

Fig. 161: Attaching the knob tool

! Risk of injury due to short-circuiting when touching the electronics.

- Always hold the electronic knob by the battery pack.

! Electrostatic discharge (sparks or flashover) can destroy electronic components.

- Therefore, before dismantling / assembling the knob sleeve, prevent electrostatic charges or touch a conductive, earthed object (e.g. a water pipe or heater) to electrostatically discharge yourself.

! Incorrect pulling may damage the battery cables.

- Pull the plug and the cables at the same time.
- Pull the battery plug (4) out of the battery socket.
- Remove the used battery pack (5) in the direction of the arrow.

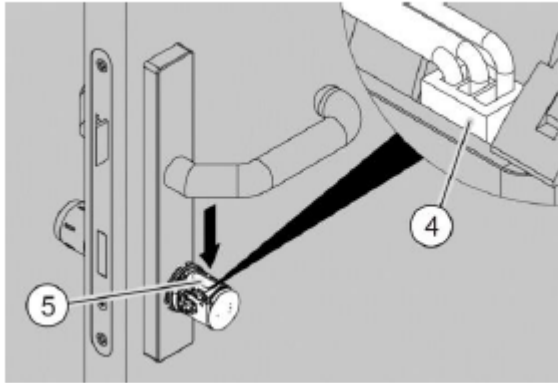

Fig. 162: Removing the battery pack

✿ The battery plug is designed to be torsion-proof by means of a guide nose.

- Insert a new battery pack into the battery socket (5).
- Insert the battery plug (4) as shown and push it until you hear it click into place. Then push the cables into the corresponding groove (not shown) below the plug.

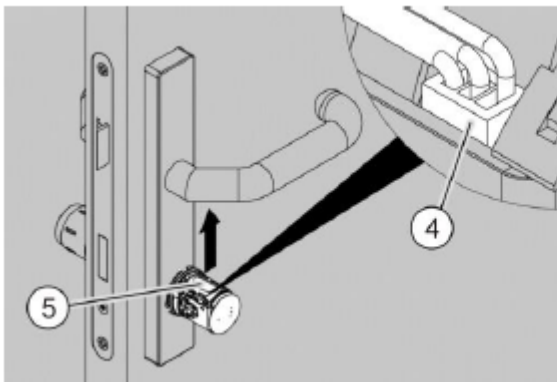

Fig. 163: Inserting the battery pack

The electronic knob performs a battery check if it was at a battery warning level before the battery change and then restarts. If there was no battery warning level, you can indicate the battery change to the electronic knob with the battery change card or the specialist dealer battery change card (without any reference to the system).

- Precisely slide the knob sleeve (1) over the electronic knob. The knob sleeve (1) can only be slid on in one position because the two driving cams on the electronic knob have different widths.

- Insert the pins of the knob tool (2) into the recesses of the bayonet disc (3).

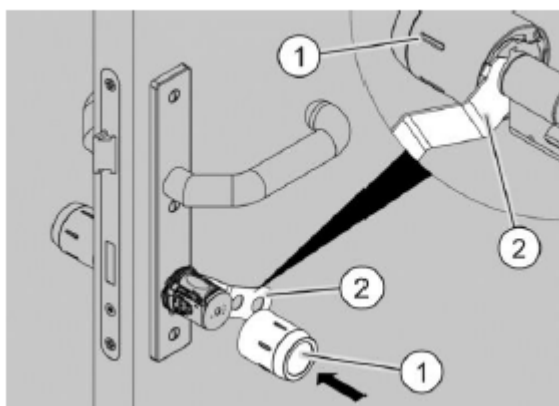

Fig. 164: Assembling the knob sleeve

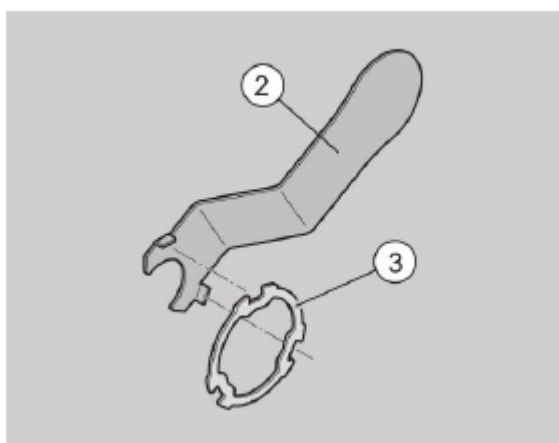

Fig. 165: Attaching the knob tool

- To lock the bayonet lock, turn the bayonet disc (3) clockwise with the knob tool (2).
- Check whether the cylinder is working properly once the batteries have been changed by holding an authorised transponder in front of it.

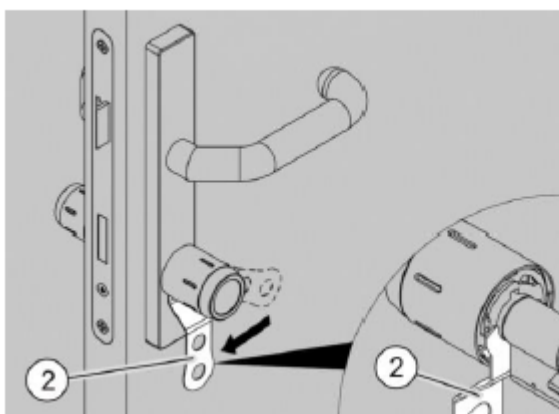

Fig. 166: Locking the bayonet lock

Additionally proceed as follows if you have changed the battery pack on the EE (Emergency Exit) cylinder:

- Check the escape and rescue route according to the specifications set down by the door, lock and handle manufacturer and carry out a function test as follows:
- Turn the engaged electronic knob slightly more than a quarter turn clockwise or anti-clockwise (11 o'clock or 1 o'clock position) as shown in Figs. A and B.
In both cases, the electronic knob must automatically return to the neutral position (see Fig. C).
- If the electronic knob does not turn back, realign the cylinder and inspect the lock for any defects.
- If you move the electronic knob by about half a turn, the reading knob remains in this position (dead centre area) due to the design.
- Then ensure that the escape door lock can be safely unlocked and opened according to the specifications set down by the lock and handle manufacturer.

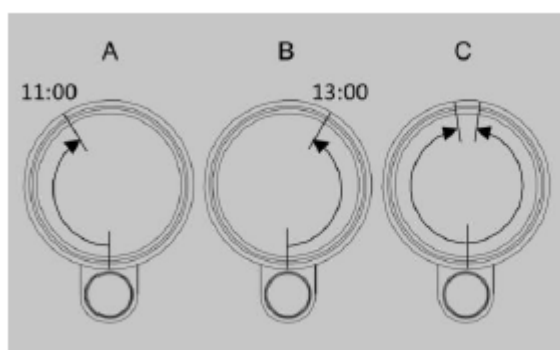

Fig. 167: Checking the function

7.1.2. Changing the padlock's battery pack

Proceed as follows to change the padlock's battery pack:

- Loosen the screws (2) with the TORX screwdriver (T10) and remove the protective cap (1).

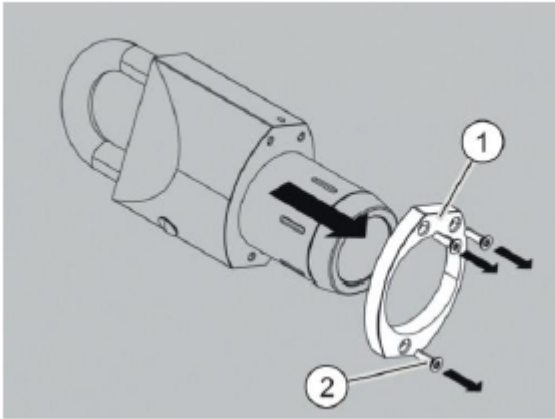

Fig. 168: Dismantling the protective cap

- Unlock the bayonet lock with the knob tool (4). Insert the pins of the knob tool (4) into the recesses of the bayonet disc (5) as shown below.
- Turn the bayonet disc (5) anti-clockwise with the knob tool (4).
- Carefully pull off the knob sleeve (3) in the direction of the arrow.

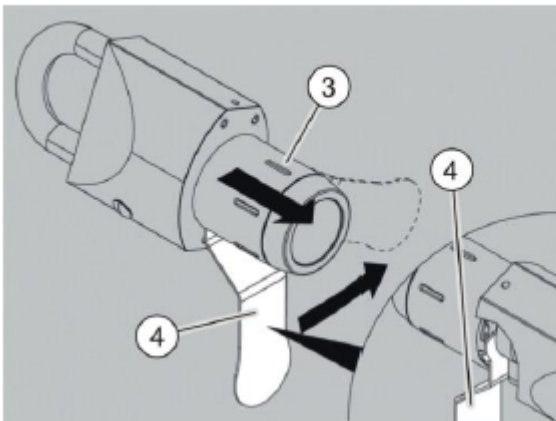

Fig. 169: Dismantling the knob sleeve

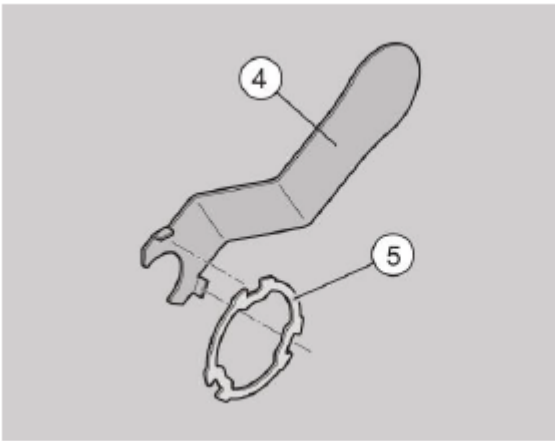

Fig. 170: Attaching the knob tool

! Risk of injury due to short-circuiting when touching the electronics.

- Always hold the electronic knob by the battery pack.

! Electrostatic discharge (sparks or flashover) can destroy electronic components.

- Therefore, before dismantling / assembling the knob sleeve, prevent electrostatic charges or touch a conductive, earthed object (e.g. a water pipe or heater) to electrostatically discharge yourself.

! Incorrect pulling may damage the battery cables.

- Pull the plug and the cables at the same time.
- Pull the battery plug (7) out of the battery socket.
- Remove the used battery pack (6) in the direction of the arrow.

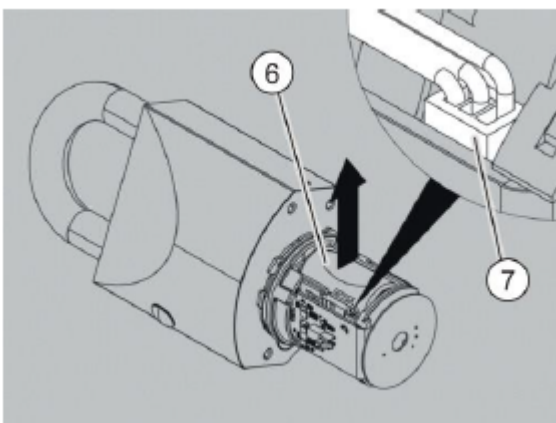

Fig. 171: Removing the battery pack

p(banner tip).The battery plug is designed to be torsion-proof by means of a guide nose.

- Insert a new battery pack into the battery socket (6).
- Insert the battery plug (7) as shown and push it until you hear it click into place. Then push the cables into the groove (not shown) below the plug.

The electronic knob performs a battery check if it was at a battery warning level before the battery change and then restarts. If there was no battery warning level, you can indicate the battery change to the electronic knob with the battery change card or the specialist dealer battery change card (without any reference to the system).

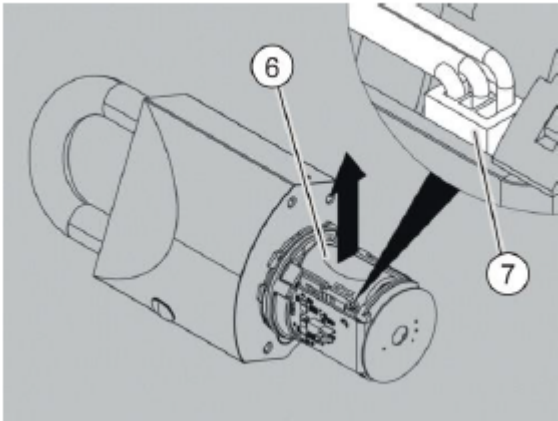

Fig. 172: Inserting the battery pack

- Attach the knob tool (4) to the bayonet lock. Insert the pins of the knob tool (4) into the recesses of the bayonet disc (5) as shown below.
- Precisely slide the knob sleeve (3) over the electronic knob (8). The knob sleeve (3) can only be slid on in one position because the two driving cams on the electronic knob (8) have different widths.

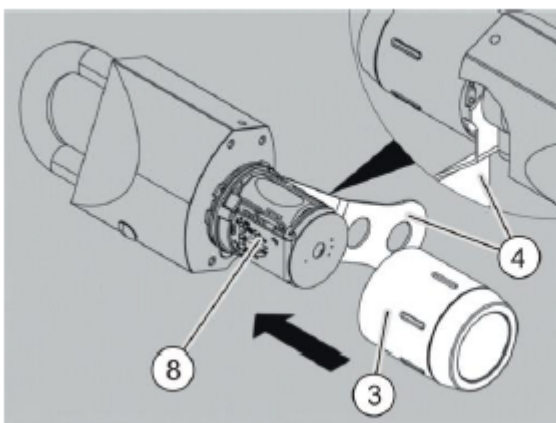

Fig. 173: Assembling the knob sleeve

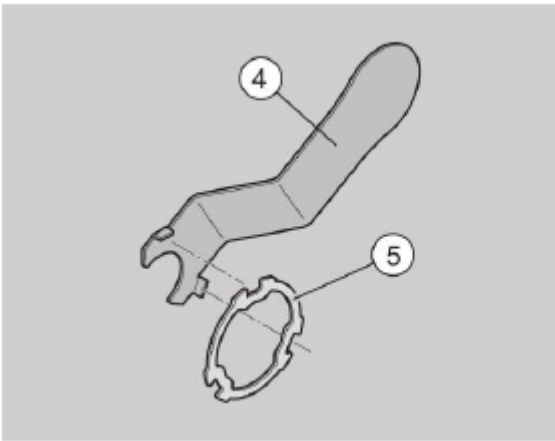

Fig. 174: Attaching the knob tool

- To lock the bayonet lock, turn the bayonet disc (5) clockwise with the knob tool (4).

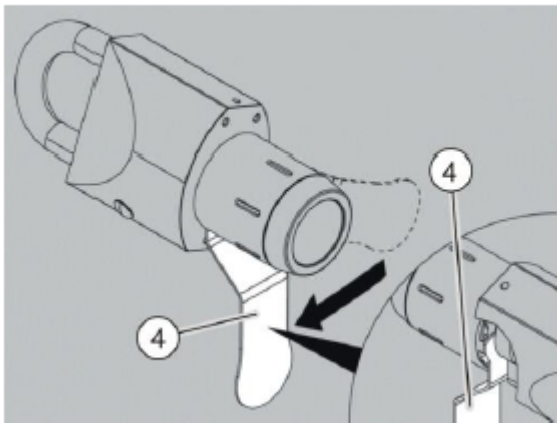

Fig. 175: Locking the bayonet lock

- Attach the protective cap (1) and tighten the screws using the TORX screwdriver (T10) so that they are hand-tight.

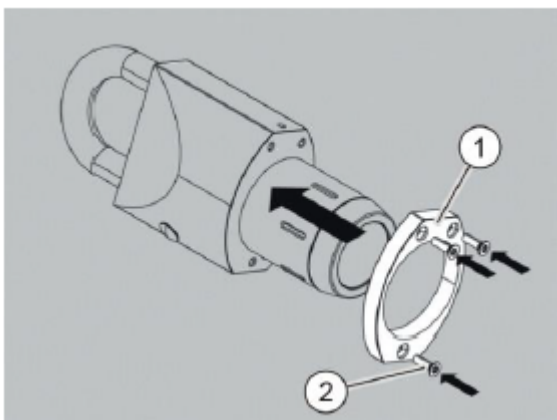

Fig. 176: Assembling the protective cap

7.2. Caring for the cylinder

! Cylinder damage caused by the use of cleaning agents.

- Do not use cleaning agents when cleaning.
- Ensure that no liquid gets into the electronic knob.

- Only clean the cylinder's and the padlock's housing with a soft, damp chamois.

8. Dismantling the cylinder

The cylinders are always dismantled in reverse order to assembly (please refer to page 28 onwards regarding this matter).

9. Disposing of the cylinder

Once its service life has elapsed, you can return the cylinder to the manufacturer in its original packaging. The manufacturer will dispose of the cylinder and the batteries it contains in an environmentally friendly manner.

Alternatively, have an approved specialist disposal company dispose of the cylinder. Observe and follow the applicable regulations. In case of doubt, please contact your town/city or municipal administration.

The cylinder is mainly made of brass. It is also made of the following materials:

- Stainless steel
- Zamac
- Electronic components
- Batteries.



10. Contact

Please consult the branch in your country directly if you have additional questions.

DOM SICHERHEITSTECHNIK GMBH & CO.KG
DE – 50321 Brühl
www.dom-group.eu

DOM SICHERHEITSTECHNIK GMBH
A – 1140 Vienna
www.dom.at

DOM NEDERLAND NL – 2491 DH
The Hague
www.dom-group.nl

DOM SCHWEIZ AG
CH – 8852 Altendorf
www.dom-group.ch

HOBERG NV
B – 1300 Wavre
www.hoberg.be

DOM-POLSKA SP. Z O.O.
PL – 42-202 Częstochowa
www.dom-polska.pl

DOM – CR S.P.A.
IT – 10154 Turin
www.dom-cr.it

DOM-UK LTD.
GB – Oldbury, B69 4LT
www.dom-security.com/uk/en

DOM-MÉTALUX S.A.S.
F – 52115 Saint-Dizier
www.dom-europe.com

DOM CZECH SPOL. S R.O.
CZ – 180 00 Prague
www.dom-czech.cz

DOM-TITAN
SI – 1241 Kamnik
www.titan.si

DOM RONIS S.A.S
F – 18600 Sancoins
www.dom-security.com/fr

EURO-ELZETT KFT.
HU – 9400 Sopron
www.euro-elzett-hu

MCM S.A.
ES – 01013 Vitoria-Gasteiz
www.mcm.es

UCEM
ES – 01013 Vitoria-Gasteiz
www.ucem.es

ANTIPANIC S.p.a.
IT – 40013 Castelmaggiore
www.antipanic.it

DOM Sicherheitstechnik GmbH &
Co.KG is part of the DOM Security
Group headquartered in France
DOM SECURITY S.A.
F – 75017 Paris
www.dom-security.com